

P160

INDIAN ASSOCIATION OF PHYSICS TEACHERS

NATIONAL STANDARD EXAMINATION IN PHYSICS 2016 -17

Date of Examination: 27TH November, 2016

Time: 0830 to 1030 Hrs

Q. Paper Code: P160

Write the question paper code mentioned above on YOUR answer sheet (in the space provided), otherwise your answer sheet will NOT be assessed. Note that the same Q. P. Code appears on each page of the question paper.

Instructions to Candidates –

1. Use of mobile phones, smartphones, ipads during examination is **STRICTLY PROHIBITED**.
2. In addition to this question paper, you are given answer sheet along with Candidate's copy.
3. On the answer sheet, make all the entries carefully in the space provided **ONLY** in **BLOCK CAPITALS** as well as by properly darkening the appropriate bubbles.
Incomplete/ incorrect/carelessly filled information may disqualify your candidature.
4. On the answer sheet, use only **BLUE or BLACK BALL POINT PEN** for making entries and filling the bubbles.
5. The email ID and date birth entered in the answer sheet will be your login credentials for accessing performance report. Please take care while entering.
6. Question paper has two parts. In part A1 (Q. No. 1 to 60) each question has four alternatives, out of which **only one** is correct. Choose the correct alternative and fill the appropriate bubble, as shown.

Q. No. 22 a b c d

In part A2 (Q. No. 61 to 70) each question has four alternatives out of which **any number of alternative (1, 2, 3 or 4) may be correct**. You have to choose ALL correct alternatives and fill the appropriate bubbles, as shown

Q. No.64 a b c d

7. For **Part A1**, each correct answer carries 3 marks whereas 1 mark will be deducted for each wrong answer. In **Part A2**, you get 6 marks if all the correct alternatives are marked. No negative marks in this part.
8. Any rough work should be done only in the space provided.
9. Use of **non-programmable** calculator is allowed.
10. No candidate should leave the examination hall before the completion of the examination.
11. After submitting your answer paper, take away the Candidate's copy for your reference.

Please DO NOT make any mark other than filling the appropriate bubbles properly in the space provided on the answer sheet.

Answer sheets are evaluated using machine, hence CHANGE OF ENTRY IS NOT ALLOWED.

Scratching or overwriting may result in a wrong score.

DO NOT WRITE ON THE BACK SIDE OF THE ANSWER SHEET.

Instructions to Candidates (continued) –

Read the following instructions after submitting the answer sheet.

12. Comments regarding this question paper, if any, may be sent by email only to iapt.nse@gmail.com till 29th November, 2016.
13. The answers/solutions to this question paper will be available on our website – www.iapt.org.in by 2nd December, 2016.
14. **CERTIFICATES and AWARDS –**
Following certificates are awarded by the IAPT to students successful in NSEs
 - (i) Certificates to “Centre Top 10%” students
 - (ii) Merit Certificates to “Statewise Top 1%” students
 - (iii) Merit Certificates and a book prize to “National Top 1%” students
15. Result sheets can be downloaded from our website in the month of February. The “Centre Top 10%” certificates will be dispatched to the Prof-in-charge of the centre by February, 2017.
16. List of students (with centre number and roll number only) having score above MAS will be displayed on our website (www.iapt.org.in) by 22nd December, 2016. See the **Eligibility Clause** in the Student’s brochure on our website.
17. Students eligible for the INO Examination on the basis of selection criteria mentioned in Student’s brochure will be informed accordingly.

Physical constants you may need...

Magnitude of charge on electron $e = 1.60 \times 10^{-19}$ C	Mass of electron $m_e = 9.10 \times 10^{-31}$ kg
Universal gas constant $R = 8.31$ J/mol K	Planck constant $h = 6.62 \times 10^{-34}$ Js
Stefan constant $\sigma = 5.67 \times 10^{-8}$ W/m ² K ⁴	Boltzmann constant $k = 1.38 \times 10^{-23}$ J/K
Mass of proton $m_p = 1.67 \times 10^{-27}$ kg	Faraday constant = 96,500 C/mol
Boiling point of nitrogen = 77.4 K	Boiling point of oxygen = 90.19 K
Boiling point of hydrogen = 20.3 K	Boiling point of helium = 4.2 K
Universal gravitational constant $G = 6.67 \times 10^{-11}$ Nm ² / Kg ²	Permittivity of free space $\epsilon_0 = 8.85 \times 10^{-12}$ C ² /Nm ²

INDIAN ASSOCIATION OF PHYSICS TEACHERS
NATIONAL STANDARD EXAMINATION IN PHYSICS 2016-17
Total Time : 120 minutes (A-1 and A-2)

A – 1

ONLY ONE OUT OF FOUR OPTIONS IS CORRECT.

- 1) Vectors **A**, **B**, **C** lie in XY plane and their resultant is **R**. The magnitudes of **A**, **B** and **R** are 100, 200 and 200 respectively. The angles made by these vectors with the positive direction of X axis are 60° , 150° , and 90° respectively. Therefore, the magnitude and the angle made by **C** with positive direction of X axis respectively are
- (a) 75, 315° (b) 110, 45° (c) 156, 240° (d) 124, 6.2°
- 2) Two particles A and B are situated 10 m apart along X axis, B being farther right of A, at $t = 0$. Particle A is moving at 0.75 m/s parallel to +Y axis while B at 1 m/s along $-X$ axis. After a time t they come closest to each other. Therefore, t is
- (a) 4.8 s (b) 6.4 s (c) 6.0 s (d) 3.2 s
- 3) Out of the following differential equations, one that correctly represents the motion of a second's pendulum is
- (a) $\frac{d^2x}{dt^2} + \frac{x}{\pi} = 0$ (b) $\frac{d^2x}{dt^2} + \frac{x}{\pi^2} = 0$ (c) $\frac{d^2x}{dt^2} + \pi x = 0$ (d) $\frac{d^2x}{dt^2} + \pi^2 x = 0$
- 4) A block of mass 2 kg drops vertically from a height of 0.4 m onto a spring whose force constant K is 1960 N/m. Therefore, the maximum compression of the spring is
- (a) 0.40 m (b) 0.25 m (c) 0.80 m (d) 0.1 m
- 5) Two blocks of masses $m_1 = 8$ kg and $m_2 = 7$ kg are connected by a light string passing over a light frictionless pulley. The mass m_1 is at rest on the inclined plane and mass m_2 hangs vertically. The angle of inclination is 30° . Therefore, the force of friction acting on m_1 is
- (a) 30 N up the plane (b) 30 N down the plane
(c) 40 N up the plane (d) 40 N down the plane
- 6) At a certain height h above the surface of the earth the change in the value of acceleration due to gravity (g) is the same as that at a depth x below the surface. Assuming h and x to be enough small compared to the radius of the earth, $x : h$ is
- (a) 1 : 1 (b) 2 : 1 (c) 1 : 2 (d) 1 : 4
- 7) Two point masses m_1 and m_2 are connected at the ends of a light rigid rod of length l . The moment of inertia of the system about an axis through their centre of mass and perpendicular to the rod is
- (a) $\frac{1}{2} \left(\frac{m_1 m_2}{m_1 + m_2} \right) l^2$ (b) $\left(\frac{m_1 m_2}{m_1 + m_2} \right) l^2$ (c) $(m_1 + m_2) l^2$ (d) $[m_1^2 + m_2^2] \left(\frac{m_1 + m_2}{m_1 m_2} \right) l^2$

P160

- 8) Two particles of masses m and M are initially at rest and infinitely separated. At a later instant when they are at a finite distance d from each other, their relative velocity of approach is

(a) $\left[\frac{Gm}{2d}\right]^{\frac{1}{2}}$ (b) $\left[\frac{2G(m+M)}{d}\right]^{\frac{1}{2}}$ (c) $\left[\frac{G(m+M)}{2d}\right]^{\frac{1}{2}}$ (d) $\left[\frac{2GM}{d}\right]^{\frac{1}{2}}$

- 9) Two blocks of masses m and $2m$ are placed on a smooth horizontal surface as shown. In the first case only a force f_1 is applied from left. Later on only a force f_2 is applied from right. If the force acting at the interface of the two blocks in the two cases is the same, then $f_1 : f_2$ is

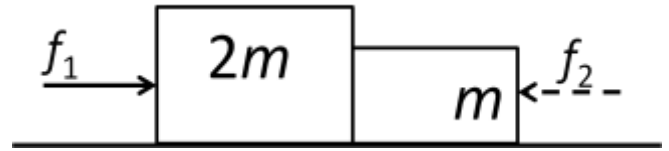

(a) 1 : 1 (b) 1 : 2 (c) 2 : 1 (d) 1 : 3

- 10) A ball A of mass 1 kg moving at a speed of 5 m/s strikes tangentially another ball B initially at rest. The ball A then moves at right angles to its initial direction at a speed of 4 m/s. If the collision is elastic, the mass (in kg) of ball B and its momentum after collision (in kg-m/s) respectively are (approximately)

(a) 1.2 and 1.8 (b) 2.2 and 3.3 (c) 4.6 and 6.4 (d) 6.2 and 9.1

- 11) A simple pendulum has a bob of mass m and a light string of length l . The string is replaced by a uniform rod of mass m and of the same length l . The time period of this pendulum is

(a) $2\pi(l/g)^{1/2}$ (b) $2\pi(8l/9g)^{1/2}$ (c) $2\pi(9l/8g)^{1/2}$ (d) $2\pi(2l/3g)^{1/2}$

- 12) A tennis ball is released from a height and allowed to fall onto a hard surface. The adjacent graph shows the variation of velocity of the ball with time from the instant of release. The point of upward maximum velocity of the ball is indicated by point

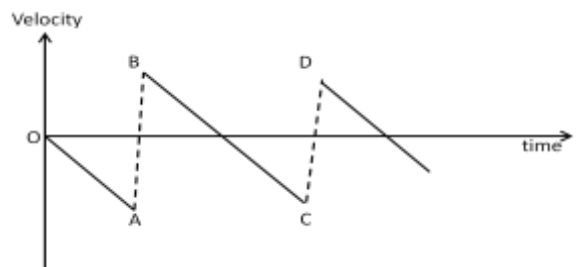

(a) A (b) B (c) C (d) D

- 13) The diagram shows an oscillating block connected to two identical springs. The frequency of oscillations can be increased substantially by

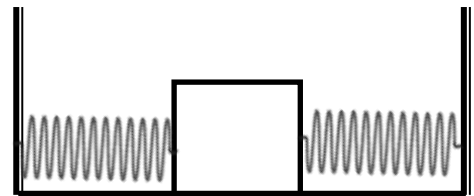

- (a) Increasing the amplitude of the oscillations.
 (b) Fixing an extra mass to the block.
 (c) Using softer pair of springs.
 (d) Using harder pair of springs.

P160

- 14) The variation of velocity with time of a toy car moving along a straight line is as shown below. Which of the following graphs correctly represents the variation of acceleration with time for the toy car?

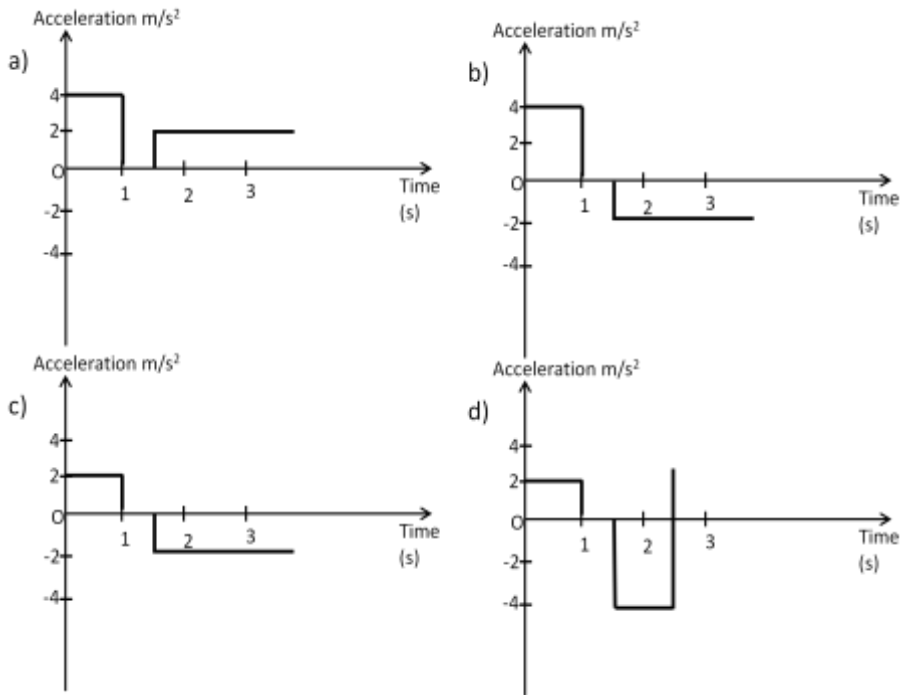
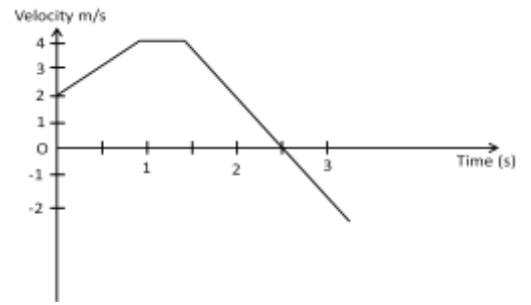

- 15) Consider a relation connecting three physical quantities A , B and C given by $A = B^n C^m$. The dimensions of A , B and C are $[LT]$, $[L^2T^{-1}]$ and $[LT^2]$ respectively. Therefore, the exponents n and m have values

- (a) $2/3$ and $1/3$ (b) 2 and 3 (c) $4/5$ and $-1/5$ (d) $1/5$ and $3/5$

- 16) Two identical rooms in a house are connected by an open doorway. The temperatures in the two rooms are maintained at two different values. Therefore,

- (a) The room with higher temperature contains more amount of air.
 (b) The room with lower temperature contains more amount of air.
 (c) Both the rooms contain the same amount of air.
 (d) The room with higher pressure contains more amount of air

- 17) A vibrator of frequency f is placed near one end of a long cylindrical tube. The tube is fitted with a movable piston at the other end. An observer listens to the sound through a side opening. As the piston is moved through 8.75 cm, the intensity of sound recorded by the observer changes from a maximum to a minimum. If the speed of sound in air is 350 m/s, the frequency f is

- (a) 500 Hz (b) 1000 Hz (c) 2000 Hz (d) 4000 Hz

P160

- 18) A heavy metal block is dragged along a rough horizontal surface at a constant speed of 20 km/hr. The coefficient of friction between the block and the surface is 0.6. The block is made of a material whose specific heat is $0.1 \text{ cal/g-}^\circ\text{C}$ and absorbs 25% of heat generated due to friction. If the block is dragged for 10 min, the rise in temperature of the block is about ($g = 10 \text{ m/s}^2$)
- (a) 12°C (b) 50°C (c) 210°C (d) data insufficient
- 19) A gas is made to undergo a change of state from an initial state to a final state along different paths by adiabatic process only. Therefore,
- (a) The work done is different for different paths.
(b) The work done is the same for all paths.
(c) There is no work done as there is no transfer of energy.
(d) The total internal energy of the system will not change.
- 20) The critical angle between a certain transparent medium and air is φ . A ray of light travelling through air enters the medium at an angle of incidence equal to its polarizing angle θ . Therefore, the angle of refraction is
- (a) $\tan^{-1}(\sin\theta)$ (b) $\tan^{-1}(\sin\varphi)$ (c) $\sin^{-1}(\tan\theta)$ (d) $\sin^{-1}(\tan\varphi)$
- 21) If a copper wire is stretched to make its radius decrease by 0.1%, the percentage change in its resistance is approximately
- (a) $- 0.4\%$ (b) $+ 0.8\%$ (c) $+ 0.4\%$ (d) $+ 0.2\%$
- 22) Consider a manual camera with a lens having a focal length of 5 cm. It is focused at infinity. For catching the picture of an object at a distance of 30 cm, one would
- (a) move the lens out by about 1 cm.
(b) move the lens out by about 5 cm.
(c) move the lens in by about 1 cm.
(d) find it impossible to catch the picture.
- 23) Initially interference is observed with the entire experimental set up inside a chamber filled with air. Now the chamber is evacuated. With the same source of light used, a careful observer will find that
- (a) The interference pattern is almost absent as it is very much diffused.
(b) There is no change in the interference pattern.
(c) The fringe width is slightly decreased.
(d) The fringe width is slightly increased.

P160

- 24) Two identical loudspeakers, placed close to each other inside a room, are supplied with the same sinusoidal voltage. One can imagine a pattern around the loudspeakers with areas of increased and decreased sound intensity alternately located. Which of the following actions will NOT change the locations of these areas?
- (a) Moving one of the speakers.
 - (b) Changing the amplitude of the signal voltage.
 - (c) Changing the frequency of the signal voltage.
 - (d) Replacing the air in the room with a different gas.
- 25) A particle at rest explodes into two fragments of masses m_1 and m_2 ($m_1 > m_2$) which move apart with nonzero velocities. If λ_1 and λ_2 are their de Broglie wavelengths respectively, then
- (a) $\lambda_1 > \lambda_2$
 - (b) $\lambda_1 < \lambda_2$
 - (c) $\lambda_1 = \lambda_2$
 - (d) data insufficient
- 26) The breakdown field for air is about 2×10^6 volt/m. Therefore, the maximum charge that can be placed on a sphere of diameter 10 cm is
- (a) 2.0×10^{-4} C
 - (b) 5.6×10^{-7} C
 - (c) 5.6×10^{-2} C
 - (d) 2.0×10^2 C
- 27) A wire in the shape of a square frame carries a current I and produces a magnetic field B_s at its centre. Now the wire is bent in the shape of a circle and carries the same current. If B_c is the magnetic field produced at the centre of the circular coil, then B_s/B_c is
- (a) $8\pi^2$
 - (b) $8\pi^2/\sqrt{2}$
 - (c) $8\sqrt{2}/\pi^2$
 - (d) $8\pi\sqrt{2}$
- 28) A solid wooden block with a uniform cross section is floating in water (density ρ_w) with a height h_1 below water. Now a flat slab of stone is placed over the wooden block but the block still floats with a height h_2 below water. Afterwards the stone is removed from the top and pasted at the bottom of the wooden block. The wooden block now floats with a height h_3 under water. Therefore, the density of the stone is
- (a) $\frac{h_2-h_1}{h_3-h_1} \rho_w$
 - (b) $\frac{h_2-h_3}{h_2-h_1} \rho_w$
 - (c) $\frac{h_2-h_1}{h_2-h_3} \rho_w$
 - (d) $\frac{h_3}{h_2-h_1} \rho_w$
- 29) Two wires made of the same material, one thick and the other thin, are connected to form a composite wire. The composite wire is subjected to some tension. A wave travelling along the wire crosses the junction point. The characteristic that undergoes a change at the junction point is
- (a) Frequency only.
 - (b) Speed of propagation only.
 - (c) Wavelength only.
 - (d) The speed of propagation as well as the wavelength.

P160

30) Ultraviolet light of wavelength 300 nm and intensity 1 W/m^2 falls on the surface of a photosensitive material. If one percent of the incident photons produce photoelectrons then the number of photoelectrons emitted per second from an area of 1 cm^2 of the surface is nearly

- (a) 1.51×10^{13} (b) 1.51×10^{12} (c) 4.12×10^{13} (d) 2.13×10^{11}

31) Two particles of masses m_1 and m_2 carry identical charges. Starting from rest they are accelerated through the same potential difference. Then they enter into a region of uniform magnetic field and move along circular paths of radii R_1 and R_2 respectively. Therefore, the ratio of their masses $m_1 : m_2$ is

- (a) $R_1 : R_2$ (b) $R_1^2 : R_2^2$ (c) $R_2^2 : R_1^2$ (d) $\sqrt{R_1} : \sqrt{R_2}$

32) A fixed horizontal wire M carries 200 A current. Another wire N running parallel to M carries a current I and remains suspended in a vertical plane below M at a distance of 20 mm. Both the wires have a linear mass density 10^{-2} kg/m . Therefore, the current I is

- (a) 20 A (b) 4.9 A (c) 49 A (d) 200 A

33) An unpolarized light of intensity 32 W/m^2 passes through three polarizers, such that the transmission axis of last polarizer is crossed with that of the first. If the intensity of emergent light is 3 W/m^2 , then the angle between the transmission axes of the first two polarizers is

- (a) 30° (b) 19° (c) 45° (d) 90°

34) An electron is injected directly towards the centre of a large metal plate having a uniform surface charge density of $-2.0 \times 10^{-6} \text{ C/m}^2$. The initial kinetic energy of the electron is $1.6 \times 10^{-17} \text{ J}$. The electron is observed to stop as it just reaches the plate. Therefore, the distance between the plate and the point from where the electron was injected is

- (a) $4.4 \times 10^{-4} \text{ m}$ (b) 4.4 m (c) $4.4 \times 10^{-2} \text{ m}$ (d) data insufficient

35) Graphs (drawn with the same scale) showing the variation of pressure with volume for a certain gas undergoing four different cyclic processes A, B, C and D are given below.

The cyclic process in which the gas performs the greatest amount of work is

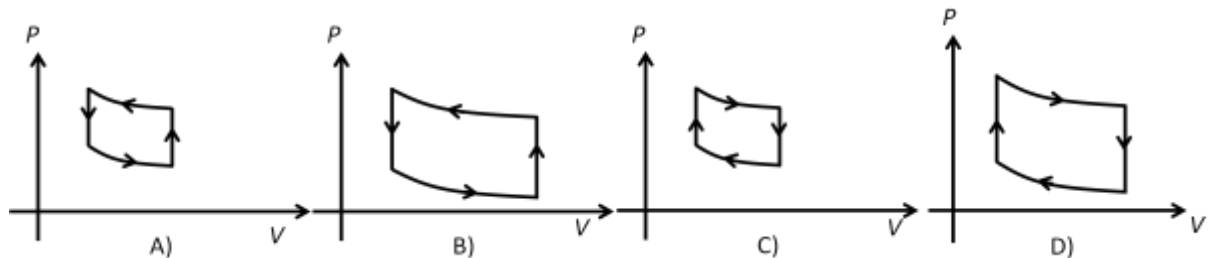

- (a) A (b) B (c) C (d) D

P160

- 41) The adjacent figure shows $I - V$ characteristics of a silicon diode. In this connection three statements are made - (I) the region OC corresponds to reverse bias of the diode, (II) the voltage at point A is about 0.2 volt, and (III) different scales have been used along +ve and -ve directions of Y axis. Therefore,

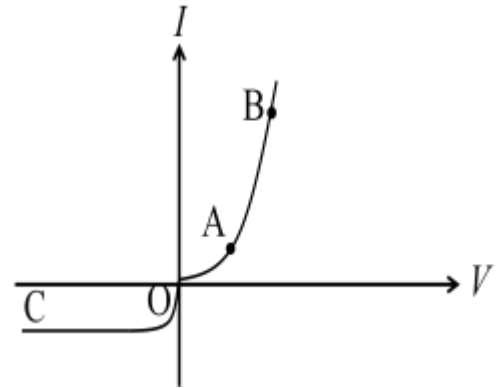

- (a) only statement (I) is correct.
 (b) only statements (I) and (II) are correct.
 (c) only statements (I) and (III) are correct.
 (d) all statements (I), (II) and (III) are correct.
- 42) Two identical lenses made of the same material of refractive index 1.5 have the focal length 12 cm. These lenses are kept in contact and immersed in a liquid of refractive index 1.35. The combination behaves as
- (a) convex lens of focal length 27 cm.
 (b) concave lens of focal length 6 cm.
 (c) convex lens of focal length 9 cm.
 (d) convex lens of focal length 6 cm.
- 43) A cup of water is placed in a car moving at a constant acceleration a to the left. Inside the water is a small air bubble. The figure that correctly shows the shape of the water surface and the direction of motion of the air bubble is

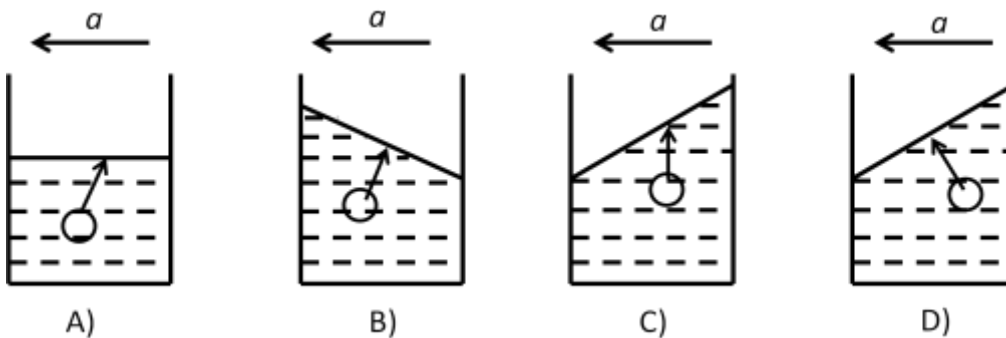

- (a) A (b) B (c) C (d) D

- 44) A sphere of radius R made up of Styrofoam (light polystyrene material) has a cavity of radius $R/2$. The centre of the cavity is situated at a distance of $R/2$ from the centre of the Styrofoam sphere. The cavity is filled with a solid material of density five times that of Styrofoam. Now, the centre of mass is seen to be located at a distance x from the centre of Styrofoam sphere, therefore x is
- (a) $R/2$ (b) $R/3$ (c) $R/4$ (d) $R/6$

P160

45) A resistor R is connected to a parallel combination of two identical batteries each with emf E and an internal resistance r . The potential drop across the resistance R is

- (a) $\frac{2ER}{2R+r}$ (b) $\frac{ER}{R+2r}$ (c) $\frac{ER}{2R+r}$ (d) $\frac{2ER}{R+2r}$

46) An ac source (sinusoidal source with frequency 50 Hz) is connected in series with a rectifying diode, a 100Ω resistor, a $1000 \mu\text{F}$ capacitor and a milliammeter. After some time the milliammeter reads zero. The voltage measured across the capacitor with a dc voltmeter is

- (a) the peak voltage of the ac source.
(b) rms voltage of the ac source.
(c) average voltage of the ac source over a half cycle.
(d) average voltage of the ac source over a full cycle.

47) The frequency of the sound produced by a siren increases from 400 Hz to 1200 Hz while its amplitude remains the same. Therefore, the ratio of the intensity of the 1200 Hz wave to that of the 400 Hz wave is

- (a) 1 : 1 (b) 3 : 1 (c) 1 : 9 (d) 9 : 1

48) The fundamental frequency of the output of a bridge rectifier driven by ac mains is

- (a) 50 Hz (b) zero (c) 100 Hz (d) 25 Hz

49) The force of attraction between the positively charged nucleus and the electron in a hydrogen atom is given by $f = k \frac{e^2}{r^2}$. Assume that the nucleus is fixed. The electron, initially moving in an orbit of radius R_1 jumps into an orbit of smaller radius R_2 . The decrease in the total energy of the atom is

- (a) $\frac{ke^2}{2} \left(\frac{1}{R_1} - \frac{1}{R_2} \right)$ (b) $\frac{ke^2}{2} \left(\frac{R_1}{R_2^2} - \frac{R_2}{R_1^2} \right)$ (c) $\frac{ke^2}{2} \left(\frac{1}{R_2} - \frac{1}{R_1} \right)$ (d) $\frac{ke^2}{2} \left(\frac{R_2}{R_1^2} - \frac{R_1}{R_2^2} \right)$

50) It is observed that some of the spectral lines in hydrogen spectrum have wavelengths almost equal to those of the spectral lines in He^+ ion. Out of the following the transitions in He^+ that will make this possible is

- (a) $n = 3$ to $n = 1$ (b) $n = 6$ to $n = 4$ (c) $n = 5$ to $n = 3$ (d) $n = 3$ to $n = 2$

Group of Q. Nos. 51 to 54 is based on the following paragraph.

A nichrome wire AB, 100 cm long and of uniform cross section is mounted on a meter scale, the ends A and B coinciding with 0 cm and 100 cm marks respectively. The wire has a resistance $S = 50 \text{ ohm}$. A point C along this wire, between A and B is called a variable point to which one end of an electrical element is connected. In the following questions this arrangement will be referred to as 'wire AB'.

- 51) The emf of a battery is determined using the following circuit with 'wire AB'. The galvanometer shows zero deflection when one of its terminals is connected to point C. If the internal resistance of the battery is 4 ohm, its emf is

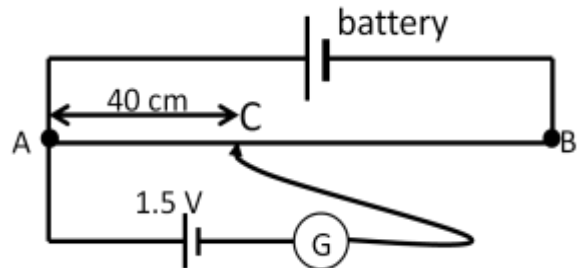

- (a) 3.75 volt (b) 4.05 volt
(c) 2.50 volt (d) 9.0 volt

- 52) In the adjacent circuit arrangement it is found that deflection in the galvanometer is 10 divisions. Also the voltage across the 'wire AB' is equal to that across the galvanometer. Therefore, the current sensitivity of the galvanometer is about

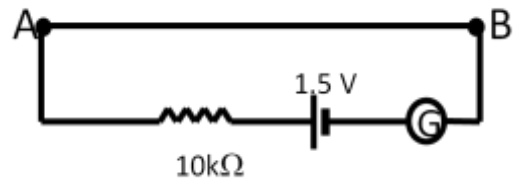

- (a) 0.050 div/ μA . (b) 0.066 div/ μA . (c) 0.010 div/ μA . (d) data insufficient.

- 53) The 'wire AB' is now a part of the adjacent circuit. With the resistors $P = 50 \Omega$ and $Q = 100 \Omega$, the null point is obtained at C where $AC = 33 \text{ cm}$. When the resistors are interchanged, the null point is found at C with $AC = 67 \text{ cm}$. The systematic error in this experiment seems to be due to non-coincidence of A and B with 0 cm mark and 100 cm mark respectively. If these end errors are equivalent to 'a' cm and 'b' cm respectively, then they are

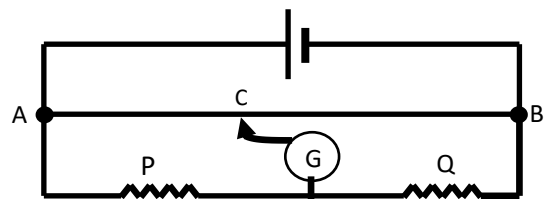

- (a) 0 and 1. (b) 1 and 0. (c) 0.33 and 0.33 (d) 1 and 1

- 54) In the adjacent circuit a resistance R is used. Initially with 'wire AB' not in the circuit, the galvanometer shows a deflection of d divisions. Now, the 'wire AB' is connected parallel to the galvanometer and the galvanometer shows a deflection nearly $d/2$ divisions. Therefore

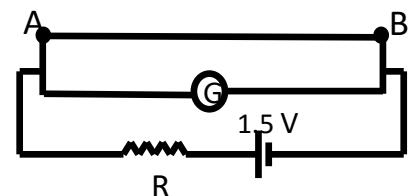

- (a) $R = G$ (b) $R \ll G$
(c) $R \gg G$ (d) $R = \frac{SG}{S+G}$

P160

Group of Q. Nos. 55 to 60 is based on the following paragraph.

A wheel of a car is made up of two parts (1)the central metal rim, and (2)the rubber tyre. The width of the tyre $W = 16.5$ cm and height $h = 10.7$ cm. The rim overlaps the tyre. The total weight of the car is 1500 kg distributed evenly. The tyres are inflated with air to a pressure 2.0 kg/cm². The density of air at pressure of 1.0 kg/cm² and at room temperature equals 1.29 g/litre. The outer diameter of the tyre is 55.4 cm and that of the rim is 40 cm.

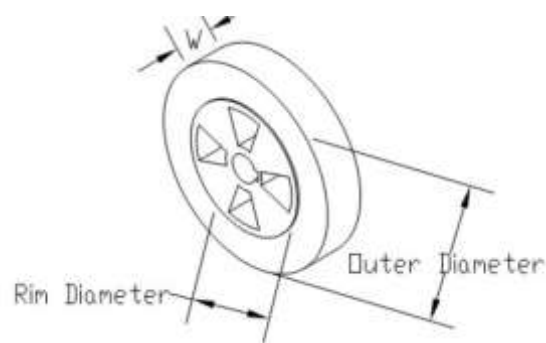

Ignore the thickness of rubber and use the dimensions given here.

Note that the units mentioned above are conventional units used in everyday life.

- 55) Consider the following two statements about a tyre of a car.
Statement A: 'The horizontal road surface is exactly tangential to the tyre.'
Statement B: 'The tyre is inflated with excess pressure.'
Which of the following alternatives is correct?
- (a) Statement A is the result of statement B.
(b) Statement B cannot be true.
(c) Statement A cannot be true.
(d) Neither of the statements A and B is true.
- 56) The left side front tyre was observed to be in contact with the road over a length L cm. The value of L is
(a) 8.85 cm (b) 9.35 cm (c) 11.36 cm (d) 10.35 cm
- 57) When five persons occupy the seats L increases by 2.5 cm. The average weight of a person is
(a) 66 kg (b) 60 kg (c) 62 kg (d) 64 kg
- 58) If five persons occupy the seats, the centre of the wheel is lowered by about
(a) 1 mm (b) 2 mm (c) 3 mm (d) 4 mm
- 59) The mass of air in a tyre is about
(a) 24 g (b) 49 g (c) 32 g (d) 64 g
- 60) The tyres of racing cars are very wide. Their width is nearly three times the above value. This large width is for
(a) stability and acceleration.
(b) streamlining and acceleration.
(c) streamlining and stability.
(d) streamlining, stability and acceleration.

A 2

In Q. Nos. 61 to 70 any number of options (1 or 2 or 3 or all 4) may be correct. You are to identify all of them correctly to get 6 marks. Even if one answer identified is incorrect or one correct answer is missed, you get zero marks.

61) A particle moves in XY plane according to the relations $x = kt$ and $y = kt(1 - pt)$ where k and p are positive constants and t is time. Therefore,

- (a) the trajectory of the particle is a parabola.
- (b) the particle has a constant velocity along X axis.
- (c) the force acting on the particle remains in the same direction even if both k and p are negative constants.
- (d) the particle has a constant acceleration along $-Y$ axis.

62) A charge q is situated at the origin. Let \mathbf{E}_A , \mathbf{E}_B and \mathbf{E}_C be the electric fields at the points $A(2, -3, -1)$, $B(-1, -2, 4)$ and $C(2, -4, 1)$. Therefore,

- (a) $\mathbf{E}_A \perp \mathbf{E}_B$.
- (b) no work is done in moving a test charge q_0 from B to C.
- (c) $2 |\mathbf{E}_A| = 3 |\mathbf{E}_B|$
- (d) $\mathbf{E}_B = -\mathbf{E}_C$

63) A uniform spherical charge distribution of radius R produces electric fields \mathbf{E}_1 and \mathbf{E}_2 at two points at distances r_1 and r_2 respectively from the centre of the distribution. Out of the following the possible expression/s for $\frac{E_1}{E_2}$ is /are

- (a) $\frac{r_2}{r_1}$
- (b) $\left[\frac{r_1}{r_2}\right]^2$
- (c) $\frac{R^3}{r_1^2 r_2}$
- (d) $\frac{r_1 r_2^2}{R^3}$

64) A metallic wire of length l is held between two supports under some tension. The wire is cooled through θ° . Let Y be the Young's modulus, ρ the density and α the thermal coefficient of linear expansion of the material of the wire. Therefore, the frequency of oscillations of the wire varies as

- (a) \sqrt{Y}
- (b) $\sqrt{\theta}$
- (c) $\frac{1}{l}$
- (d) $\sqrt{\frac{\alpha}{\rho}}$

65) Water is flowing through a vertical tube with varying cross section as shown. The rate of flow is 52.5 ml/s. Given that speed of flow $v_1 = 0.35$ m/s and area of cross section $A_2 = 0.5$ cm². Which of the following is/are true?

- (a) $A_1 = 1.0$ cm², $v_2 = 0.70$ m/s.
- (b) $A_1 = 1.5$ cm², $v_2 = 1.05$ m/s.
- (c) $h = 5$ cm.
- (d) $h = 10$ cm.

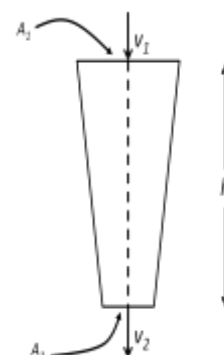

P160

- 66) A simple laboratory power supply consists of a transformer, bridge rectifier and a filter capacitor. It drives a suitable load. If due to some reason one of the diodes in the rectifier circuit becomes open, then
- output voltage of power supply falls to zero.
 - output voltage of power supply decreases to some nonzero value.
 - ac ripple in the output increases.
 - ripple frequency decreases.
- 67) Circuit A is a series LCR circuit with $C_A = C$ and $L_A = L$. Another circuit B has $C_B = 2C$ and $L_B = L/2$. Both the circuits have the same resistance and the capacitor and the inductance are assumed to be ideal components. Each of the circuits is connected to the same sinusoidal voltage source. Therefore,
- both the circuits have the same resonant frequency.
 - both the circuits carry the same peak current.
 - resonance curve for circuit A is more sharp than that for circuit B.
 - resonance curve for circuit B is more sharp than that for circuit A.

- 68) The variation of acceleration with time for a particle performing simple harmonic motion along straight line is as in adjacent figure. Therefore,

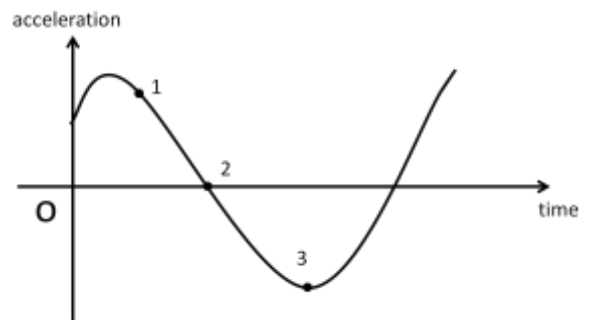

- the particle has a non-zero displacement initially.
 - the displacement of the particle at point 1 is negative.
 - the velocity of the particle at point 2 is positive.
 - the potential energy at point 3 is maximum.
- 69) Which of the following physical quantities have dimensions identical to each other?
- the Young's modulus Y .
 - $\epsilon_0 E^2$ where E is the electric field intensity and ϵ_0 is the permittivity of free space.
 - $\frac{B^2}{\mu_0}$ where B is the magnetic field and μ_0 is the permeability of free space.
 - kT where k is Boltzmann's constant and T is the absolute temperature.
- 70) A small ball bearing is released at the top of a long vertical column of glycerin of height $2h$. The ball bearing falls through a height h in a time t_1 and then the remaining height with the terminal velocity in time t_2 . Let W_1 and W_2 be the work done against viscous drag over these heights. Therefore,
- $t_1 < t_2$
 - $t_1 > t_2$
 - $W_1 = W_2$
 - $W_1 < W_2$

P160

Rough Sheet

P160

Rough Sheet

P160

Rough Sheet