



INDIAN ASSOCIATION OF PHYSICS TEACHERS

National Standard Examination in Physics - 2023

Date of Examination: November 26, 2023

Time: 8:30 AM to 10:30 AM

Question Paper Code: 61

Student's Roll No:									
-----------------------	--	--	--	--	--	--	--	--	--

Write the Question Paper Code (mentioned above) on YOUR OMR Answer Sheet (in the space provided), otherwise your Answer Sheet will NOT be evaluated. Note that the same Question Paper Code appears on each page of the Question Paper.

Instructions to Candidates:

1. Use of mobile phone, smart watch, and iPad during examination is **STRICTLY PROHIBITED**.
2. In addition to this Question Paper, you are given OMR Answer Sheet along with candidate's copy.
3. On the Answer Sheet, make all the entries carefully in the space provided **ONLY** in **BLOCK CAPITALS** as well as by properly darkening the appropriate bubbles.
Incomplete/ incorrect/ carelessly filled information may disqualify your candidature.
4. On the OMR Answer Sheet, use only **BLUE** or **BLACK BALL POINT PEN** for making entries and filling the bubbles.
5. Your **Ten-digit roll number and date of birth** entered on the OMR Answer Sheet shall remain your login credentials (means login id and password, respectively) for accessing your performance / result in National Standard Examination in Physics – 2023.
6. Question Paper has two parts. In part A1 (Q. No.1 to 48) each question has four alternatives, out of which **only one** is correct. Choose the correct alternative and fill the appropriate bubble, as shown.

Q.No.22 a c d

In part A2 (Q. No. 49 to 60) each question has four alternatives out of which any number of alternative (s) (1, 2, 3, or 4) may be correct. You have to choose **all** correct alternative(s) and fill the appropriate bubble(s), as shown

Q.No.54 a c

7. For **Part A1**, each correct answer carries 3 marks whereas 1 mark will be deducted for each wrong answer. In **Part A2**, you get 6 marks if all the correct alternatives are marked. No negative marks in this part.
8. Rough work may be done in the space provided. There are **13** printed pages in this paper
9. Use of **Non - programmable scientific** calculator is allowed.
10. No candidate should leave the examination hall before the completion of the examination.
11. After submitting Answer Paper, take away the Question Paper & candidate's copy of OMR sheet for your future reference.

Please DO NOT make any mark other than filling the appropriate bubbles properly in the space provided on the OMR Answer Sheet.

Answer Sheets are evaluated using machine, hence CHANGE OF ENTRY IS NOT ALLOWED. Scratching or overwriting may result in a wrong score.

DO NOT WRITE ON THE BACK SIDE OF THE ANSWER SHEET.

Instructions to Candidates (Continued) :

You may read the following instructions after submitting the Answer Sheet.

12. Comments/Inquiries/Grievances regarding this Question Paper, if any, can be shared on the Inquiry/Grievance column on www.iapt.org.in on the specified format till Dec 3, 2023

13. The Answers/Solutions to this Question Paper will be available on the website: www.iapt.org.in by Dec 2, 2023. The score card may be downloaded after Dec 24, 2023

14. CERTIFICATES and AWARDS:

Following certificates shall be awarded by IAPT to the students, successful in the NATIONAL STANDARD EXAMINATION IN PHYSICS – 2023

- (i) “CENTRE TOP 10 %” To be downloaded from iapt.org.in after 30.01.24
- (ii) “STATE TOP 1 %” Will be dispatched to the examinee
- (iii) “NATIONAL TOP 1 %” Will be dispatched to the examinee
- (iv) “GOLD MEDAL & MERIT CERTIFICATE” to all students who attend OCSC – 2024 at HBCSE Mumbai

Certificate for centre toppers shall be uploaded on iapt.org.in

15. List of students (with centre number and roll number only) having score above **Minimum Admissible Score (MAS) will be displayed on the website: www.iapt.org.in by **Dec 26, 2023**. See the **MAS clause** on the Student’s brochure on the web.**

16. List of students eligible to appear for Indian National Physics Olympiad (INPhO – 2024) shall be displayed on www.iapt.org.in by Dec 30, 2023.

Physical constants you may need....

Magnitude of charge on electron $e = 1.60 \times 10^{-19} C$	Avogadro’s constant $A = 6.023 \times 10^{23} mol^{-1}$
Mass of electron $m_e = 9.11 \times 10^{-31} kg$	Speed of light in free space $c = 3 \times 10^8 ms^{-1}$
Mass of proton $m_p = 1.67 \times 10^{-27} kg$	Speed of sound in dry air at 0°C $v = 332 ms^{-1}$
Acceleration due to gravity $g = 9.81 ms^{-2}$	Permittivity of free space $\epsilon_0 = 8.85 \times 10^{-12} C^2 / Nm^2$
Universal gravitational constant $G = 6.67 \times 10^{-11} Nm^2 / kg^2$	Permeability of free space $\mu_0 = 4\pi \times 10^{-7} Hm^{-1}$
Universal gas constant $R = 8.31 J / mol K$	Planck’s constant $h = 6.625 \times 10^{-34} Js$
Boltzmann constant $k = 1.38 \times 10^{-23} J / K$	Faraday constant = 96,500 $C mol^{-1}$
Stefan’s constant $\sigma = 5.67 \times 10^{-8} W / m^2 K^4$	Rydberg constant $R = 1.097 \times 10^7 m^{-1}$
Atmospheric pressure (at STP) = $1.013 \times 10^5 Nm^{-2}$	Astronomical unit = $1.50 \times 10^{11} m$

INDIAN ASSOCIATION OF PHYSICS TEACHERS
NATIONAL STANDARD EXAMINATION IN PHYSICS
(NSEP – 2023)

Time: 120 minute

Max. Marks: 216

Attempt All the Sixty Questions

A – 1

ONLY ONE OUT OF FOUR OPTIONS IS CORRECT. BUBBLE THE CORRECT OPTION.

1. Two balls are projected from the top of a cliff with equal initial speed u . One starts at angle θ above the horizontal while the other starts at angle θ below. Difference in their ranges on ground is

(a) $2 \frac{u^2 \tan \theta}{g}$ (b) $\frac{u^2 \sin 2\theta}{2g}$ (c) $\frac{u^2 \sin 2\theta}{g}$ (d) $\frac{u^2 \cos 2\theta}{g}$

2. A solid block of mass 3 kg is suspended from the bottom of a 5 kg block with the help of a rope AB of mass 2 kg as shown in the figure. When pulled by an upward force F , the whole system experiences an upward acceleration $a = 2.19 \text{ ms}^{-2}$. Choose the correct option

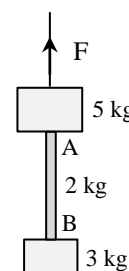

- (a) Net force on the rope AB is 24 N
 (b) Tension at the midpoint of the rope AB is 48 N
 (c) Force F is 20 N
 (d) Force F is 60 N

3. A block P of mass 0.4 kg is attached to a vertical rotating spindle by two strings AP and BP of equal length 1.0 m as shown in the figure. The period of rotation is 1.2 s. Tensions T_1 and T_2 in string AP and BP are

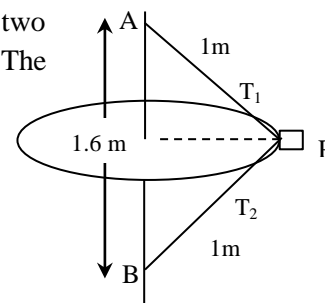

- (a) $T_1 = 15.86 \text{ N}$ $T_2 = 10.97 \text{ N}$
 (b) $T_1 = 15.86 \text{ N}$ $T_2 = 3.04 \text{ N}$
 (c) $T_1 = 7.94 \text{ N}$ $T_2 = 3.03 \text{ N}$
 (d) $T_1 = T_2 = 5.48 \text{ N}$

4. A particle of mass m moves in a straight line under the influence of a certain force such that the power (P) delivered to it remains constant. Starting from rest, the straight line distance traveled by the moving particle in time t is

(a) $\left(\frac{8Pt^3}{27m} \right)^{\frac{1}{2}}$ (b) $\left(\frac{4Pt^3}{27m} \right)^{\frac{1}{2}}$ (c) $\left(\frac{8Pt^2}{9m} \right)^{\frac{1}{2}}$ (d) $\left(\frac{8Pt^3}{9m} \right)^{\frac{1}{2}}$

5. A bullet is fired vertically up with half the escape speed from the surface of the Earth. The maximum altitude reached by it (ignore the effect of rotation of the Earth) in terms of radius of Earth R is

(a) $\frac{R}{3}$ (b) $\frac{R}{2}$ (c) R (d) $\frac{2R}{3}$

6. A **can** is a hollow cylinder of radius R and height h . Its ends are sealed with circular sheets of the same material. The can is made of thin sheet metal of areal mass density σ (kg/m^2). Moment of inertia of this closed **can** about its vertical axis of symmetry is

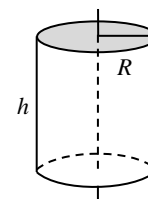

- (a) $\pi R^3 \sigma (h + 2R)$ (b) $\pi R^3 \sigma (h + R)$
 (c) $\pi R^3 \sigma (2h + R)$ (d) $2\pi R^3 \sigma (h + R)$

7. A particle of mass m is revolving in a horizontal circle on a frictionless horizontal table with the help of a string tied to it and passing through a hole at the center of the table. Two equal masses M are attached to the other end of the string as shown. If one of the hanging masses M is removed gently, the radius of the circular motion of m

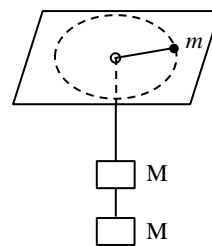

- (a) decreases by a factor 1.414
 (b) increases by a factor 1.260
 (c) increases by a factor 1.414
 (d) does not change because of the conservation of angular momentum.

8. Three stars of equal mass M rotate in a circular path of radius r about their center of mass such that the stars always remain equidistant from each other. The common angular speed (ω) of rotation of the stars can be expressed as

(a) $\left(\frac{GM\sqrt{3}}{r^3}\right)^{\frac{1}{2}}$ (b) $\left(\frac{GM}{r^3}\right)^{\frac{1}{2}}$ (c) $\left(\frac{GM}{r^3} \frac{2}{\sqrt{3}}\right)^{\frac{1}{2}}$ (d) $\left(\frac{GM}{r^3\sqrt{3}}\right)^{\frac{1}{2}}$

9. The density of a liquid is ρ at the surface. The bulk modulus of the liquid is B . The increase $\Delta\rho$ in the density of the liquid at a depth h from the surface is (with $\Delta\rho \ll \rho$)

(a) $\Delta\rho = \frac{\rho^2 g h}{B}$ (b) $\Delta\rho = \frac{\rho g h}{B}$ (c) $\Delta\rho = \frac{\rho^2 g h}{2B}$ (d) $\Delta\rho = \frac{2\rho^2 g h}{B}$

10. Water flows at 1.2 m/s through a hose of diameter 1.59 cm. The time required to fill a cylindrical container of radius 2 m to a height of $h = 1.25$ m will be nearly

(a) 18.3 hour (b) 2.7 hour (c) 550 min (d) 220 min

11. A police car, moving at speed of 108 km/hour, approaches a truck moving at 72 km/hour in opposite direction. The natural frequency of the siren of the car is 800 Hz and the surrounding temperature is 27°C . The frequency heard by the truck driver as the car passes him

- (a) remains unchanged (b) decreases nearly by 232 Hz
 (c) increases nearly by 231 Hz (d) decreases nearly by 260 Hz

12. A rope of mass M and length L hangs vertically. Time needed for a transverse pulse to travel from its bottom end to the support is

(a) $\sqrt{\frac{2L}{g}}$ (b) $2\sqrt{\frac{L}{g}}$ (c) $\sqrt{\frac{L}{g}}$ (d) $\sqrt{\frac{L}{2g}}$

13. The figure shows a smooth tunnel AB ($length = 2\ell$) in a uniform density planet (say Earth) of mass M and radius R . A small ball of mass m is released from rest at the end A of the tunnel. Acceleration due to gravity at surface of the planet is g . Time taken by the ball to reach the end B is

(a) $\pi\sqrt{\frac{R}{g}}$ (b) $2\sqrt{\frac{\ell}{g}}$
 (c) $\frac{\pi}{2}\sqrt{\frac{2R}{g}}$ (d) $2\pi\sqrt{\frac{R}{g}}$

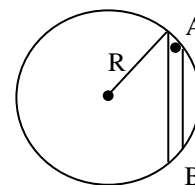

14. When the speaker S_1 is switched ON, the sound intensity at a point P in a room is 80 dB. But when the speaker S_2 is switched ON (S_1 is switched OFF), the sound intensity at the same point P in the room is 85 dB. The sound intensity level (in dB) at the same point P in the room, if the two speakers S_1 and S_2 are simultaneously switched ON, is (consider the speakers to be incoherent)
- (a) 165 dB (b) 86.2 dB (c) 87.8 dB (d) 88.6 dB

15. A block B of mass 0.5 kg moving, on a horizontal frictionless table at 2.0 ms^{-1} , collides with a massless pan P (at origin O) and sticks to it. The pan is connected at the end of a horizontal un-stretched (relaxed) spring of force constant $K = 32 \text{ Nm}^{-1}$ as shown in figure. After the block collides, the displacement $x(t)$ of the block as a function of time t is given by

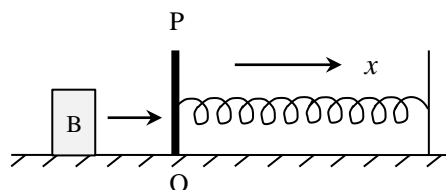

- (a) $0.25 \cos 8t \text{ m}$ (b) $0.25 \sin 8t \text{ m}$ (c) $2.50 \sin \frac{t}{8} \text{ m}$ (d) $0.50 \sin \frac{\pi}{4} t \text{ m}$

16. Which of the following functions does not represent a traveling wave

- (a) $y = A \sin^2 \left[\pi \left(t - \frac{x}{v} \right) \right]$ (b) $y = A e^{-\alpha t} \cos (kx - \omega t)$
 (c) $y = A \sin \left[(kx)^2 - (\omega t)^2 \right]$ (d) $y = A \cos \left[(kx - \omega t)^2 \right]$

17. Two Carnot heat engines are connected in series such that the sink of the first engine is heat source of the second. Efficiency of the engines are η_1 and η_2 respectively. Net efficiency η of the combination is given by

- (a) $\eta = \eta_1 + \eta_2$ (b) $\eta = \frac{\eta_1 \eta_2}{\eta_1 + \eta_2}$
 (c) $\eta = \eta_1 + \eta_2 (1 - \eta_1)$ (d) $\eta = \eta_1 - \eta_2 (1 - \eta_1)$

18. An air bubble of radius 2 mm at a depth 12 m below the surface of water at temperature of 8°C , rises to the surface where the temperature is 16°C . Neglecting the effect of Surface Tension, the radius of the bubble at the surface is estimated to be

- (a) 2.56 mm (b) 2.61 mm (c) 2.86 mm (d) 4.45 mm

19. Two soap bubbles of radii a and b coalesce to form a single bubble of radius c under isothermal conditions. If the external pressure is p_A , then the Surface Tension (T) of the soap solution is

- (a) $\frac{P_A (c^3 - a^3 - b^3)}{4 (a^2 + b^2 - c^2)}$ (b) $\frac{P_A (a^3 + b^3 - c^3)}{2 (c^2 - a^2 - b^2)}$
 (c) $\frac{P_A (a^2 + b^2 - c^2)}{2 (c^3 - a^3 - b^3)}$ (d) $\frac{P_A (c^2 - a^2 - b^2)}{4 (a + b - c)}$

20. An open-end organ pipe 30 cm in length and a closed-end organ pipe 23 cm in length, both of equal diameter, are each sounding their first overtone and both are in unison at 1100 Hz. The speed of sound in air, is estimated to be nearly

- (a) 324 ms^{-1} (b) 332 ms^{-1} (c) 340 ms^{-1} (d) 352 ms^{-1}

21. The figure shows a lagged bar XY of non-uniform cross section. One end X of the bar is maintained at 100°C and the other end Y at 0°C . The variation of temperature along its length from X to Y in steady state is best represented by the curve.

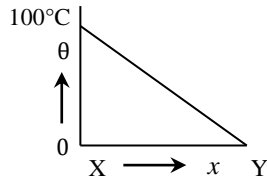
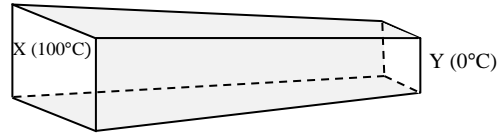

(a)

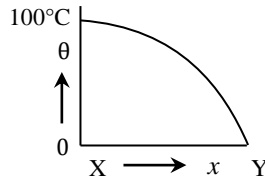

(b)

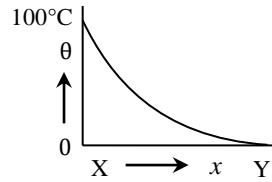

(c)

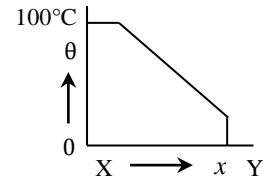

(d)

22. An ideal gas (n moles) is initially at pressure P and temperature T . It is cooled isochorically to a pressure $\frac{P}{4}$. The gas is then expanded at a constant pressure so as to attain back its initial temperature T . Work done by gas during the entire process is

(a) $\frac{5}{4}nRT$ (b) $\frac{3}{4}nRT$ (c) $\frac{1}{4}nRT$ (d) Zero

23. Assuming the Sun to be a spherical body (radius R_S) of surface temperature T , the total radiation power received by Earth (radius R_E) at a distance r from Sun is

(a) $\frac{\sigma \pi R_E^2 R_S^2 T^4}{r^2}$ (b) $\frac{\sigma 4 \pi R_E^2 R_S^2 T^4}{r^2}$ (c) $\frac{\sigma \pi R_E^2 R_S^2 T^4}{4r^2}$ (d) $\frac{\sigma R_E^2 R_S^2 T^4}{4 \pi r^2}$

24. The figure shows five point-charges on a straight line. Separation between successive charges is 10 cm. For what values of q_1 and q_2 would the net force on each of the other three charges be zero?

(a) $q_1 = q_2 = -\frac{27}{80} \mu\text{C}$ (b) $q_1 = q_2 = \frac{27}{40} \mu\text{C}$
 (c) $q_1 = \frac{27}{80} \mu\text{C}$ $q_2 = -\frac{27}{80} \mu\text{C}$ (d) $q_1 = q_2 = -\frac{27}{40} \mu\text{C}$

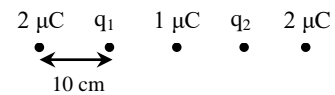

25. Two equal blocks, each of mass M , hang on either side of a frictionless light pulley with a light string. A rider of mass m is placed on one of the blocks (as shown). When the system is released, the block with rider descends a distance H till the rider is caught by a ring that allows the block to pass through. The system moves a further distance D taking time t . In such a situation, the acceleration due to gravity is

(a) $g = \frac{(2M + m)D^2}{2mHt^2}$ (b) $g = \frac{(M + m)D^2}{2mHt^2}$
 (c) $g = \frac{(2M + m)D}{mHt^2}$ (d) $g = \frac{(M + 2m)D^2}{mHt^2}$

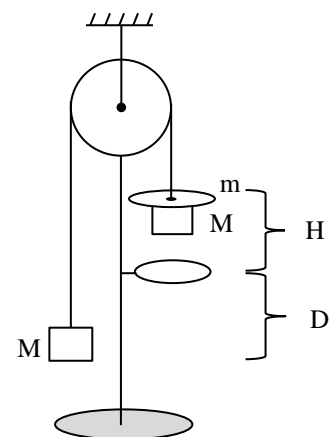

26. A very small electric dipole of dipole moment \vec{p} lies along the x axis (i.e. $\vec{p} = p\hat{i}$) in a non-uniform electric field $\vec{E} = \frac{c}{x}\hat{i}$ (where c is a constant). The force on the dipole is

- (a) $\frac{cP}{x^2}\hat{i}$ (b) $-\frac{cP}{x^2}\hat{i}$ (c) $\frac{cP}{x}\hat{i}$ (d) zero

27. A conducting thick spherical shell of radii a and b ($b > a$) has been charged with uniform surface charge density $-\sigma$ C/m^2 on the inner and $+\sigma$ C/m^2 on the outer surfaces. Then

- (a) the net charge on the spherical shell is zero.
 (b) the radial electric field outside the shell is $E = \frac{\sigma b^2}{\epsilon_0 r^2}$
 (c) a radial electric field $E = \frac{\sigma(b^2 - a^2)}{\epsilon_0 r^2}$ exists outside the shell.
 (d) there is a net electric charge in the cavity (i.e. in region $r < a$) equal to $4\pi\sigma(b^2 - a^2)$

28. A spherical conductor is charged up to a potential of 450 V. The potential outside, at a distance 15 cm from the surface, is 300 V. Then

- (a) the potential at 15 cm from the center is 900 V
 (b) the charge on the conductor is 1.5 nC
 (c) the electric field just outside the surface is 150 N/C
 (d) the total electrical energy of the conductor is $U = 3.375 \mu J$

29. Capacitors $C_1 = 3 \mu F$, $C_2 = 6 \mu F$, $C_3 = 4 \mu F$ and $C_4 = 1 \mu F$ are connected in a circuit as shown to a battery of 60 V. Now if key K is closed, the charge that will flow through K is

- (a) $90 \mu C$ from b to a (b) $60 \mu C$ from b to a
 (c) $30 \mu C$ from a to b (d) $150 \mu C$ from b to a

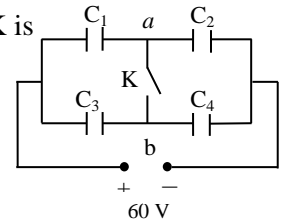

30. The electrical conductivity of a sample of semiconductor is found to increase when the electromagnetic radiation of wave length just shorter than 2480 nm is incident normally on its surface. The band gap of the semiconductor is

- (a) 1.96 eV (b) 1.12 eV (c) 0.50 eV (d) 0.29 eV

31. A U-shaped conducting wire of mass $m = 10 g$, having length of its horizontal section as $\ell = 20 cm$, is free to move vertically up and down. The two ends of the wire are immersed in mercury for proper electrical contact. The wire is in a homogeneous field of magnetic induction $B = 0.1 T$ as shown. The wire jumps up to a height $h = 3 m$ when a charge q , in the form of a current pulse, is sent through the wire. Considering that the duration of the current pulse is very small compared to the time of flight, the charge q passed through the wire is estimated to be nearly

- (a) $6.85 \mu C$ (b) $9.80 \mu C$
 (c) $2.84 C$ (d) $3.84 C$

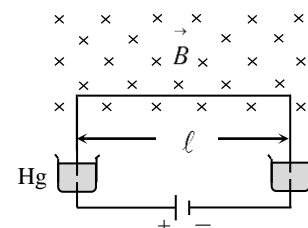

32. A target of ${}^7\text{Li}$ is bombarded with a proton beam of current 10^{-4} ampere for 1 hour to produce ${}^7\text{Be}$ of activity 1.8×10^8 disintegrations per second. Assuming that bombarding of 1000 protons produces one ${}^7\text{Be}$ radioactive nucleus, the half-life of ${}^7\text{Be}$ is estimated to be approximately
 (a) 6887 hour (b) 4332 hour (c) 2407 hour (d) 2195 hour

33. A long straight wire carrying a current $i = 10\text{ A}$ and a rectangular metallic loop of dimensions $b \times c$ lie in the same plane as shown in the figure. The parameters are $a = 10\text{ cm}$, $b = 30\text{ cm}$ and $c = 50\text{ cm}$. The mutual inductance of the system is nearly

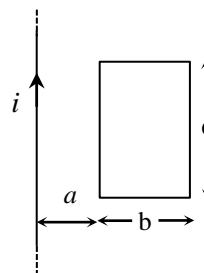

- (a) 69 nH (b) 71 nH
 (c) 139 nH (d) 281 nH

34. Impedance of a given series LCR circuit, fed with alternating current, is the same for two frequencies f_1 and f_2 . The resonance frequency f_R of the circuit is

- (a) $\frac{f_1 + f_2}{2}$ (b) $\frac{2f_1 f_2}{f_1 + f_2}$ (c) $\sqrt{f_1 f_2}$ (d) $\sqrt{f_1^2 + f_2^2}$

35. A lawn roller is a solid cylinder of mass M and radius R . As shown in the figure, it is pulled at its center by a horizontal force F and rolls without slipping on a horizontal surface. Then the

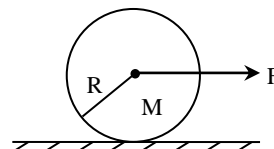

- (a) acceleration of the cylinder is $\frac{2F}{M}$
 (b) force of friction acting on the cylinder is $\frac{2F}{3M}$
 (c) coefficient of friction needed to prevent slipping is at least $\frac{F}{3Mg}$
 (d) minimum coefficient of friction to prevent slipping is $\frac{2F}{3Mg}$

36. A hydrogen atom ($m_e = 1.67 \times 10^{-27}\text{ kg}$), initially at rest, emits a photon and goes from the excited state $n = 5$ to the ground state. The recoil speed of the atom is nearly
 (a) 4.2 ms^{-1} (b) $4 \times 10^{-4}\text{ ms}^{-1}$ (c) $2 \times 10^{-2}\text{ ms}^{-1}$ (d) $8 \times 10^2\text{ ms}^{-1}$

37. Two nuclides A and B are isotopes. The nuclides B and C are isobars. All the three nuclides A, B and C are radioactive. You may then conclude that

- (a) the nuclides A, B and C must belong to the same element
 (b) the nuclides A, B and C may belong to the same element
 (c) it is possible that A may change to B through a radioactive decay process
 (d) it is possible that B may change to C through a radioactive decay process

38. Numerical aperture of an optical fibre is a measure of

- (a) the attenuation of light through it (b) its resolving power
 (c) the pulse dispersion through it (d) its light gathering power

39. Heavy stable nuclei have more neutrons than protons. This is because of the fact that
- neutrons are heavier than protons
 - the electrostatic forces between protons are repulsive
 - neutrons decay into protons through beta decay
 - the nuclear forces between neutrons are weaker than those between protons
40. An equi-concave lens of radii of curvature of the two surfaces numerically equal to 7 cm and refractive index $\mu = 1.5$ has a small silver dot on the rear surface. As a result of this, a ray of light incident parallel to the principal axis gets reflected from its rear surface and then reflected also from the inner front surface. The ray after the second reflection emerges out of the thin lens and appears to focus at a point P on the principal axis. The point P lies
- 1 cm before the lens
 - 2 cm before the lens
 - 1 cm beyond the lens
 - at none of these
41. Light emerges out uniformly from a point source placed at the focus of a concave mirror to give out a spherical wave front. As a result of reflection of the paraxial rays from the concave mirror, according to Huygen's theory the reflected light is in the form of a
- spherical wave front with centre at the focus, and radius equal to the radius of curvature of the mirror
 - spherical wave front with centre at the focus, and radius equal to the focal length of the mirror
 - cylindrical wave front with its axis coinciding with the principal axis of the mirror.
 - plane wave front perpendicular to the reflected beam
42. An equi-convex lens of focal length ' f ' is cut along a diameter, in two halves (pieces). The two identical pieces of the lens are now arranged as shown in the figure on a common axis at a separation f between the two. The image of an object AB placed at $x = 0$ **cannot** be formed at the distance $x = \xi$ from the object along the axis, for the value of ξ as

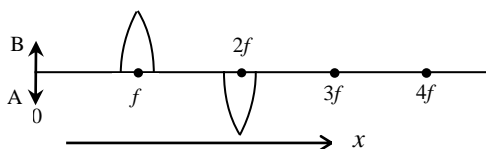

- $\xi = 2f$
 - $\xi = 3f$
 - $\xi = 4f$
 - $\xi = \infty$
43. During the processes of annihilation of a stationary electron of mass m_0 with a stationary positron of equal mass, a radiation is emitted. The wavelength of the resulting radiation is
- $\frac{h}{m_0 c}$
 - $\frac{2h}{m_0 c}$
 - $\frac{m_0}{hc}$
 - $\frac{m_0 c}{h}$
44. The convex surface of a concavo-convex lens of refractive index 1.5 and radii of curvature $R_1 = 20$ cm and $R_2 = 40$ cm has been silvered so as to make it reflecting. The distance of a luminous object from the reflecting system when placed in front of it on its principal axis, so that the image coincides with the object is
- 40 cm
 - 32 cm
 - 16 cm
 - 8 cm

45. A direct vision spectroscopy has been designed to obtain dispersion without deviation by arranging alternate inverted thin prisms of crown glass (refractive index $\mu_1 = \sqrt{2}$) and flint glass ($\mu_2 = \sqrt{3}$) with refracting angle $\theta_{\text{flint}} = 3^\circ$. The refracting angle θ_{crown} of the crown glass prism is
- (a) 3.0° (b) 4.5° (c) 5.3° (d) 6.0°
46. Continuous and Characteristic X – rays are produced when electron beam accelerated by a high potential difference of V volt (say) is made to hit the metallic target such as Molybdenum in a modern Coolidge tube. Let λ_{min} be the smallest possible wavelength of continuous X – rays and $\lambda_{L\alpha}$ be the maximum wavelength of the characteristic X- rays. Then
- (a) $\lambda_{L\alpha}$ increases with increase in V (b) $\lambda_{L\alpha}$ decreases with increase in V
(c) λ_{min} increases with increase in V (d) λ_{min} decreases with increase in V
47. While performing an experiment for determining the focal length of a concave mirror by u-v method, a student recorded the given sets of the positions (in cm) of the object and the corresponding image on the bench as (12, 51), (18, 54), (30, 50), (48, 34), (42, 42) and (78, 98). She used an optical bench of length 1.5 m and the mirror is fixed at the 90 cm mark on the bench. The maximum acceptable error in the location of the image is 0.2 cm. The reading (observation) that cannot be obtained from experimental measurement and has been incorrectly recorded, for a mirror of focal length = 24 cm, is
- (a) (18, 54) (b) (30, 50) (c) (48, 34) (d) (78, 98)
48. A parallel beam, of 6.0 mW radiation of wavelength 200 nm and of area of cross-section 1.0 mm^2 , falls normally on a plane metallic surface. If the radiations are completely reflected, the pressure exerted by the radiations on the metallic surface is estimated to be
- (a) $1 \times 10^5\text{ Pa}$ (b) $2 \times 10^5\text{ Pa}$ (c) $2 \times 10^{-5}\text{ Pa}$ (d) $4 \times 10^{-5}\text{ Pa}$

ANY NUMBER OF OPTIONS (4, 3, 2 or 1) MAY BE CORRECT
MARKS WILL BE AWARDED ONLY IF ALL THE CORRECT OPTIONS ARE BUBBLED AND NO INCORRECT.

49. The force $F(x)$ acting on a body of mass m changes with position x (in meter) as shown. It is given that the potential energy $U(x) = 0$ at $x = 0$

Choose correct option(s).

- (a) $U(x) = 0$ at $x = 0$, $x = 3$ and $x = 6$
 (b) $U(x) = 2x^2 - 12x$ for $2 \leq x \leq 4$
 (c) $U(x) = -x^2 + 12x - 40$ for $4 \leq x \leq 6$
 (d) At $x = 3$, $U(x) = -10 J$

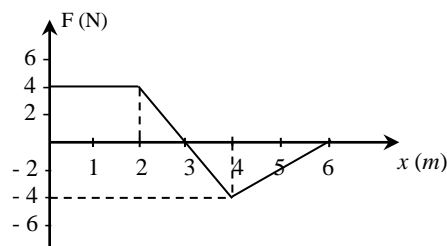

50. A deuteron of mass M moving at speed v collides elastically with an α - particle of mass $2M$, initially at rest. The deuteron is scattered through 90° from initial direction of its motion with speed V_d while the α - particle is scattered with speed V_α at an angle θ from the initial direction of motion of deuteron. Then

- (a) $\theta = 30^\circ$ (b) $V_\alpha = \frac{v}{\sqrt{3}}$
 (c) $V_d = \frac{v}{\sqrt{3}}$ (d) a fraction $\frac{2}{3}$ of energy of deuteron is transferred to α particle

51. Two plane progressive waves travelling on a string as

$$y_1 = 2.5 \times 10^{-3} \sin(30x - 420t)$$

$$y_2 = 2.5 \times 10^{-3} \sin(30x + 420t)$$

superimpose to produce a standing wave. The variables x and y are in meter and t is in second. Then

- (a) the equation of resultant standing wave is $y = 5 \times 10^{-3} \cos(30x) \sin(420t)$
 (b) the equation of resultant standing wave is $y = 2.5 \times 10^{-3} \sin(30x) \cos(420t)$
 (c) the antinode closest to $x = 0.25 m$ is at $x = 0.262 m$
 (d) the amplitude of oscillation of particle at $x = 0.17 m$ is $4.63 mm$

52. Two moles of nitrogen in a container, of negligible thermal capacity, are initially at $17^\circ C$. The gas is compressed adiabatically from an initial volume of 120 liter to 80 liter. The correct option(s) is/are

- (a) Initial pressure of the gas is nearly $40.2 kPa$
 (b) Final temperature of the gas is nearly $68^\circ C$
 (c) Work done by the gas is $2.12 kJ$
 (d) The internal energy of the gas increases by $2.12 kJ$

53. A small dipole is placed at the origin with its dipole moment $\vec{P} = p \hat{i}$ oriented along x axis. E and V , are respectively, the Electric field and potential at point $A(x, y)$. The observations at the Point $A(x, y)$ which is at a large distance r from the origin, show that

$$(a) E_x = \frac{1}{4\pi\epsilon_0} \frac{p(2x^2 - y^2)}{r^5} \qquad (b) E_x = \frac{1}{4\pi\epsilon_0} \frac{p(x^2 - 2y^2)}{r^5}$$

$$(c) E_y = \frac{1}{4\pi\epsilon_0} \frac{3pxy}{r^5} \qquad (d) V = \frac{1}{4\pi\epsilon_0} \frac{\vec{P} \cdot \vec{r}}{r^3}$$

54. Two equal positive charges $+Q$ each lie on y axis at $(0, a)$ and $(0, -a)$. The electric field strength E at a point $(x, 0)$ satisfies:

$$(a) E = \frac{1}{4\pi\epsilon_0} \frac{2Qa}{(x^2 + a^2)^{3/2}}$$

(b) for large values of x (*i.e.* $x \gg a$), the electric field $E \propto \frac{1}{x^2}$

(c) for $x \geq 0$, E is maximum at $x = \frac{a}{\sqrt{2}}$

(d) for $x \geq 0$, E is maximum at $x = 0$ and is equal to $\frac{1}{4\pi\epsilon_0} \frac{2Q}{a^2}$

55. A metal rod of mass m and length ℓ slides on frictionless parallel metal rails of negligible resistance. A resistance R is connected between the rails at their ends as shown in the figure. A uniform magnetic field B is directed into the plane of paper perpendicular to the plane of rails throughout the space. The rod is given an initial velocity v_0 (towards right). No other force acts on the rod. Then

$$(a) v(t) = v_0 e^{-\frac{B\ell t}{mR}}$$

$$(b) \text{ the rod stops after traveling a distance } x = \frac{mv_0 R}{B^2 \ell^2}$$

$$(c) \text{ the total energy dissipated in resistance is } \frac{1}{4} mv_0^2 \text{ i.e. half of the initial kinetic energy}$$

$$(d) \text{ the total charge that flows in the circuit is } q = \frac{mv_0}{B\ell}$$

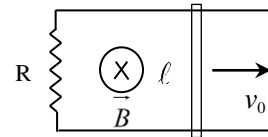

56. The magnetic field $\vec{B} = 2 \times 10^{-5} \sin \left\{ \pi \left(0.5 \times 10^3 x + 1.5 \times 10^{11} t \right) \right\} \hat{j} T$ represents a plane electromagnetic wave travelling in space with x in meter and t in second. The correct statement(s) are

- (a) The wave length of the wave is 4.0 mm and its frequency is 75 GHz
- (b) The energy density associated with the wave is nearly $= 316 \mu J / m^3$
- (c) The electric field vector is $\vec{E} = -6000 \sin \left[\pi \left(0.5 \times 10^3 x - 1.5 \times 10^{11} t \right) \right] \hat{k} Vm^{-1}$
- (d) The electric field vector is $\vec{E} = 6000 \sin \left[\pi \left(0.5 \times 10^3 x + 1.5 \times 10^{11} t \right) \right] \hat{k} Vm^{-1}$

57. In the circuit shown, the current in the 8Ω resistance across G and H is $i = 0.5$ ampere. The ammeter is ideal. The internal resistance of the cell is 0.8Ω . Choose correct option(s).

- (a) Reading of the ammeter is 1.5 ampere
 (b) Potential difference across A and H is 13 V
 (c) Potential difference across C and F is 9 V
 (d) The emf of the cell is 24 V

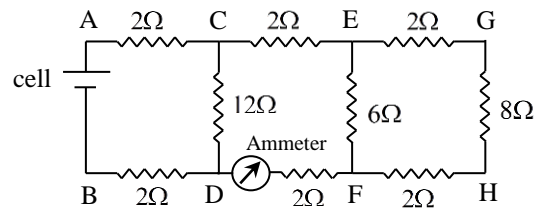

58. In an experiment with Lummer Gehrecke plate, the two coherent beams of light, caused by multiple reflections inside the transparent plate of refractive index $\mu = 1.54$, reach the points P and Q on the screen. The net path difference between the two beams reaching either at P or Q is $\Delta x = 5000\text{ nm}$. Which of the wavelengths in the visible range ($\lambda = 390\text{ nm}$ to $\lambda = 780\text{ nm}$) is/are most likely to produce a constructive interference (a maximum) at the point P as well as at Q on the screen?

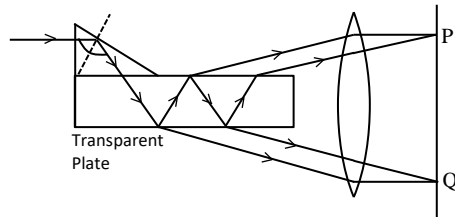

- (a) 416.67 nm (b) 555.56 nm (c) 625.00 nm (d) 666.70 nm
59. Two identical transparent solid cylinders, each of radius 10 cm and refractive index $\mu = \sqrt{3}$, lie horizontally parallel to each other on a horizontal plane mirror with a separation x between their horizontal axes. A ray of light is incident horizontally on the cylinder A at a height h above the plane mirror so as to emerge from this cylinder at a height $h_1 = 0.1\text{ m}$ above the plane mirror. The ray emerging out from the first cylinder A is reflected from the horizontal plane mirror to enter the second parallel cylinder B at a height h_2 and then this ray emerges out of the second cylinder, parallel and in-line with the original incident ray. The correct statement(s) is/are:
- (a) the height h above the plane mirror is $h = 18.7\text{ cm}$
 (b) the ray enters the second cylinder B at a height $h_2 = 0.1\text{ m}$
 (c) the separation between the axes of the two cylinders **A** and **B** is $x = 31.54\text{ cm}$
 (d) the angle of incidence on the plane mirror midway between the two cylinders is $\theta = 30^\circ$
60. In the working of a $p - n$ junction

- (a) diffusion current dominates when the junction is forward biased
 (b) drift current dominates when the junction is reverse biased
 (c) depletion region width decreases with increase in forward bias voltage.
 (d) the electric field in the depletion region depends on the number of ionized dopants rather than the dopant density.

Rough work