



**INDIAN ASSOCIATION OF PHYSICS TEACHERS**  
**NATIONAL STANDARD EXAMINATION IN BIOLOGY - 2022**

**Date of Examination: November 27, 2022**

**Time: 2:30 PM to 4:30 PM**

**Question Paper Code: 21**

Student's Roll No:									
-----------------------	--	--	--	--	--	--	--	--	--

*Write the question paper code (mentioned above) on YOUR OMR Answer Sheet (in the space provided), otherwise your Answer Sheet will NOT be evaluated. Note that the same Question Paper Code appears on each page of the question paper.*

**Instructions to Candidates:**

1. Use of mobile phone, smart watch, and ipad during examination is STRICTLY PROHIBITED
2. In addition to this question paper, you are given OMR Answer Sheet along with Candidate's copy.
3. On the OMR sheet, make all the entries carefully in the space provided **ONLY** in **BLOCK CAPITALS** as well as by properly darkening the appropriate bubbles.

**Incomplete/ incorrect/ carelessly filled information may disqualify your candidature.**

4. On the OMR Answer Sheet, use only **BLUE** or **BLACK BALL POINT PEN** for making entries and filling the bubbles.
5. Your **Ten-digit roll number and date of birth** entered on the OMR Answer Sheet shall remain your login credentials means login id and password respectively for accessing your performance / result in NSEB - 2022.
6. Question paper has two parts. In part A1 (Q. No.1 to 48) each question has four alternatives, out of which **only one** is correct. Choose the correct alternative and fill the appropriate bubble, as shown.

**Q.No. 12**    a       c    d

In part A2 (Q. No. 49 to 60) each question has four alternatives out of which any number of alternative (s) (1, 2, 3, or 4) may be correct. You have to choose all correct alternative(s) and fill the appropriate bubble(s), as shown

**Q.No. 52**    a       c  

7. For **Part A1**, each correct answer carries 3 marks whereas 1 mark will be deducted for each wrong answer. In **Part A2**, you get 6 marks if all the correct alternatives are marked. No negative marks in this part.
8. Rough work may be done in the space provided. There are 22 printed pages in this paper.
9. Use of **non - programmable scientific** calculator is allowed.
10. No candidate should leave the examination hall before the completion of the examination.
11. After submitting answer paper, take away the question paper & Candidate's copy OMR sheet for your reference.

**Please DO NOT make any mark other than filling the appropriate bubbles properly in the space provided on the OMR answer sheet.**

**OMR answer sheets are evaluated using machine, hence CHANGE OF ENTRY IS NOT ALLOWED. Scratching or overwriting may result in a wrong score.**

**DO NOT WRITE ON THE BACK SIDE OF THE OMR ANSWER SHEET.**

***Instructions to Candidates (Continued) :***

*You may read the following instructions after submitting the answer sheet.*

12. **Comments/Inquiries/Grievances regarding this question paper, if any, can be shared on the Inquiry/Grievance column on [www.iapt.org.in](http://www.iapt.org.in) on the specified format till December 3, 2022**
13. **The answers/solutions to this question paper will be available on the website: [www.iapt.org.in](http://www.iapt.org.in) by December 2, 2022.**
14. **CERTIFICATES and AWARDS:**  
 Following certificates shall be awarded by IAPT/ATBS to the students, successful in the NATIONAL STANDARD EXAMINATION IN BIOLOGY – 2022
  - (i) CENTRE TOP 10 % To be downloaded from [iapt.org.in](http://iapt.org.in) after 15.01.23
  - (ii) STATE TOP 1 % Will be dispatched to the examinee
  - (iii) NATIONAL TOP 1 % Will be dispatched to the examinee
  - (iv) GOLD MEDAL & MERIT CERTIFICATE to all students who attend OCSC – 2023 at HBCSE Mumbai

Certificate for centre toppers shall be uploaded on [iapt.org.in](http://iapt.org.in)
15. List of students (with centre number and roll number only) having score above MAS will be displayed on the website: [www.iapt.org.in](http://www.iapt.org.in) by **December 25, 2022**. See the **Minimum Admissible Score** clause on the Student's brochure on the web.
16. List of students eligible to appear for Indian National Astronomy Olympiad (INAO – 2023) shall be displayed on [www.iapt.org.in](http://www.iapt.org.in) by December 30, 2022.

**INDIAN ASSOCIATION OF PHYSICS TEACHERS  
NATIONAL STANDARD EXAMINATION IN BIOLOGY  
(NSEB - 2022)**

Time: 120 minute

Max. Marks: 216

**Attempt All Sixty Questions**

**A - 1**

**ONLY ONE OUT OF FOUR OPTIONS IS CORRECT. BUBBLE THE CORRECT OPTION.**

- Compare adults of the animals listed below and find out which animal has both higher annual energy expenditure and higher energy expenditure per unit body weight per day?  
(a) Python                      (b) Frog                      (c) Man                      (d) Penguin
- The correct sequence of arrangement in the decreasing order of size for Hemoglobin, *E.coli* ribosome and Tobacco mosaic virus (T.M.V.) is;  
(a) *E.coli* ribosome > T.M.V. > hemoglobin      (b) Hemoglobin > T.M.V. > *E.coli* ribosome  
(c) T.M.V. > hemoglobin > *E.coli* ribosome      (d) Hemoglobin > *E.coli* ribosome > T.M.V.
- Which of the following animals is triploblastic, acoelomate and with ciliated body surface?  
(a) Obelia                      (b) Taenia                      (c) Planaria                      (d) Fasciola
- Several factors can influence optimal flock size in birds. The following graph indicates % time spent in three major lifestyle habits by birds of different flock size.

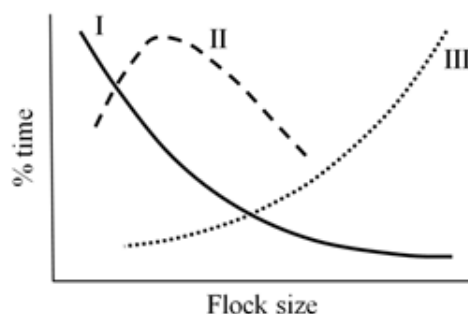

The three habits I, II and III respectively are:

- |                                 |                                 |
|---------------------------------|---------------------------------|
| (a) feeding, scanning, fighting | (b) fighting, feeding, scanning |
| (c) scanning, feeding, fighting | (d) feeding fighting, scanning  |
- Predatory insects with two pairs of functional wings with an incomplete metamorphosis are:  
(a) Dragonflies                      (b) Wasps                      (c) Caddisflies                      (d) Moths
- Which of the following tools is used to determine the 3D structure of protein?  
(a) X-rays                      (b) Mass spectrometry  
(c) Liquid chromatography                      (d) 2D gel electrophoresis

7. Among the following amino acids, arginine could have an ionic interaction with:  
 (a) Lysine                      (b) Glutamic acid      (c) Valine                      (d) Methionine
8. Embryos of reptiles, birds and mammals have extraembryonic membranes. They perform essential functions for the developing embryo.  
 Match the predominant function with each type of membrane.

	Membrane		Function
i.	Yolk sac	P.	Storing metabolic waste
ii.	Chorion	Q.	Source of food
iii.	Allantois	R.	Gas exchange
iv.	Amnion	S.	Fluid enclosing and protecting embryo

- (a) i – Q,                      ii – S,                      iii – P,                      iv – S  
 (b) i – S,                      ii – P,                      iii – Q,                      iv – R  
 (c) i – Q,                      ii – R,                      iii – P,                      iv – S  
 (d) i – S,                      ii – Q,                      iii – R,                      iv – P
9. Consider the following five animals:  
 horse, house cat, leopard, tortoise and wolf.

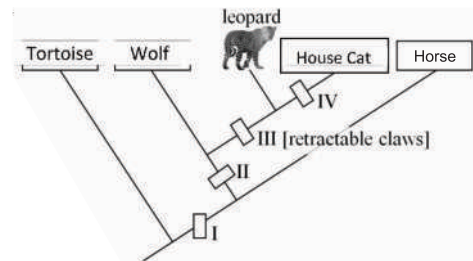

- If they have to be correctly classified cladistically using the following scheme, what will be the characters at I, II, and IV respectively?
- (a) I: carnivory      II: hair                      IV: purring  
 (b) I: hair              II: purring                      IV: carnivory  
 (c) I: purring              II: hair                      IV: carnivory  
 (d) I: hair                      II: carnivory                      IV: purring
10. Birds show an adaptive cross-connection between blood vessels that increases the flexibility of their neck. The anastomosis between blood vessels of left and right side, allowing blood to flow freely even when the head twists and one of the vessels is pinched, is:  
 (a) Carotid anastomosis                      (b) Cranial anastomosis  
 (c) Jugular anastomosis                      (d) Branchial anastomosis
11. An animal who is known to be a marsupial shows the following body features:  
 • Almost hairless big ears                      • Forelimbs with sharp claws  
 • Grey coat color                      • Long sticky snout  
 What can be deduced about the animal's habits/habitat?
- i. The animal is likely to be diurnal.                      ii. The animal is likely to dig deep burrows.  
 iii. The habitat is likely to be sandy deserts.                      iv. The animal is likely to be insectivorous.
- (a) i and ii only                      (b) ii, iii and iv only      (c) ii and iii only                      (d) all the four

12. MHC-I is expressed by almost all normal cells but not abnormal and infected cells. Cells of which of the following lymphoid lineages recognize tumor cells and virus-infected abnormal cells by the absence of MHC-I?  
 (a) Th Cells. (b) Tc Cells. (c) NK Cell. (d) B Cell
13. Empirical data suggests that optimal group size of animals is determined by costs and benefits associated with it. When predation risk and success rate were studied in prey-predator relationships, following graphs were obtained. Four possible factors that influence the group sizes of prey populations are given below.

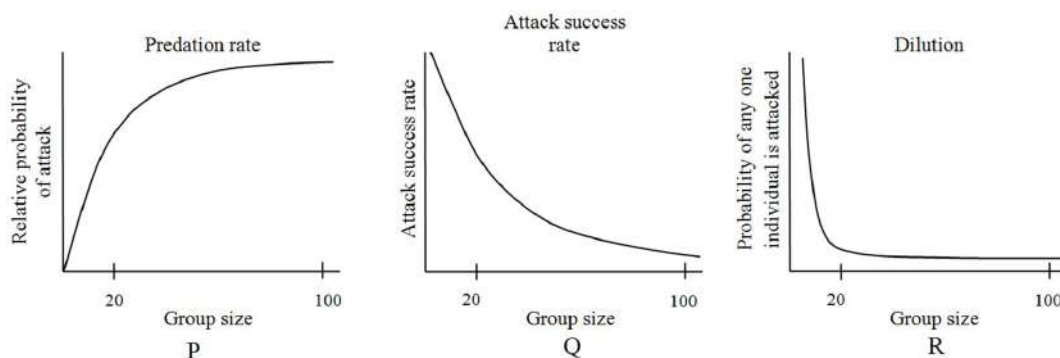

- I. Conspicuousness of group    II. Shared vigilance  
 III. Confusion effect    IV. Every individual with equal chance of being attacked
- Match these against the correct graphs marked P, Q, and R:

	<b>P</b>	<b>Q</b>	<b>R</b>
(a)	I	II, III	IV
(b)	IV	II	III, IV
(c)	IV	II, III	I
(d)	I	II, III	IV

14. In a protein structure,  $\alpha$ -helix hairpin,  $\beta$ -hairpin and  $\beta$ - $\alpha$ - $\beta$  unit are the examples of:  
 (a) Secondary structure (b) Super secondary structure  
 (c) Tertiary structure (d) Quaternary structure
15. The immunoglobulin (X) is present on mast cells and basophils. When bound to an antigen, it triggers the release of (Y) that causes (Z). Here X, Y and Z respectively refers to:  
 (a) IgA, Histamine and inflammation (b) IgM, Interleukin and allergy.  
 (c) IgE, Histamine and allergy. (d) IgD, Histamine and Interleukin.

16. Carefully observe the experimental setup given below. Hydrogen carbonate indicator is a cherry red coloured pH indicator which turns yellow in acidic conditions and purple in alkaline conditions. At the start of the experiment, equal quantities of this indicator (cherry red in colour) were added to each tube. A healthy green leaf of the same size was enclosed in each tube. The tubes were then kept for 15 min in a water bath to avoid heating due to the light source.

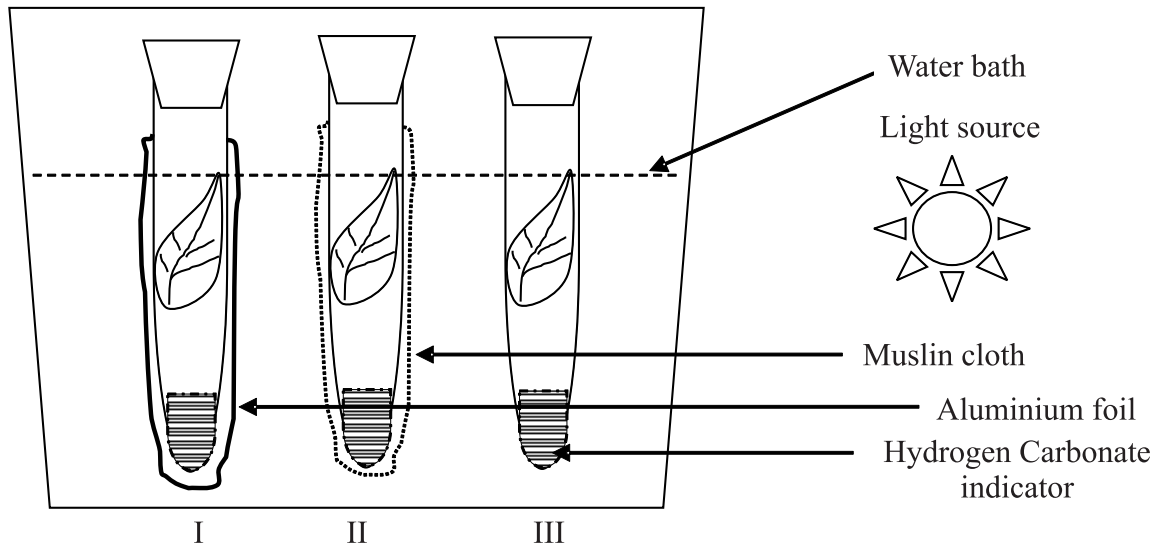

After incubation for a certain period of time, what would be the colour of the indicator in tubes I, II and III respectively?

- (a) Cherry red, Cherry red, Yellow  
 (b) Yellow, Cherry red, Purple  
 (c) Purple, Yellow, Cherry red  
 (d) Yellow, Purple, Cherry red
17. Cyanogen bromide (CNBr) is a very selective agent that splits peptide bonds on the carbonyl side of every methionine residue in a protein. The number of polypeptides that will result from cutting of given protein by CNBr is:



- (a) 3  
 (b) 4  
 (c) 5  
 (d) 6
18. A hypothetical population had alleles “A” and “a” with frequencies 0.9 and 0.1 respectively. The genotypic frequencies of “AA”, “Aa” and “aa” were 0.81, 0.18 and 0.01 respectively. Suppose a negative selection pressure acts against the dominant phenotype resulting in the reduction of the frequency of A in the present generation from 0.9 to 0.8, then the genotypic frequencies of the zygotes formed would be respectively
- (a) 0.81; 0.18 and 0.01  
 (b) 0.64; 0.32 and 0.04  
 (c) 0.8; 0.1 and 0.1  
 (d) 0.54; 0.44 and 0.02

19. While studying the effect of two plant growth regulators; IAA and Cytokinin, five different sets of culture tubes with varying concentrations of the hormones were prepared as given in the following table. Explants of parenchyma tissue derived from the stem of tobacco plant were transferred on culture medium of all sets. After a particular period of time, the **set V** showed undifferentiated large mass of tissue.

Sets	Conc. of IAA (mg dm <sup>-3</sup> )	Conc. of Cytokinin (mg dm <sup>-3</sup> )
I	-	0.2
II	2.0	-
III	2.0	0.02
IV	0.02	1.0
V	2.0	0.2

What would be the expected result of culturing in set I to IV respectively?

- (a) Shoot formation, Root formation, No growth, Cell enlargement  
 (b) No growth, Cell enlargement, Root formation, Shoot formation  
 (c) Cell enlargement, No growth, Shoot formation, Root formation  
 (d) Root formation, Shoot formation, Cell enlargement, No growth
20. Veena found a preserved root specimen in her college laboratory. The specimen jar label was half torn so she could not read the full name of the sample. She took a cross section and observed it under the microscope. She was not aware of the exact tissue types so she drew the diagram and labeled it as per her understanding. Looking at the features she mentioned, it could most likely be:

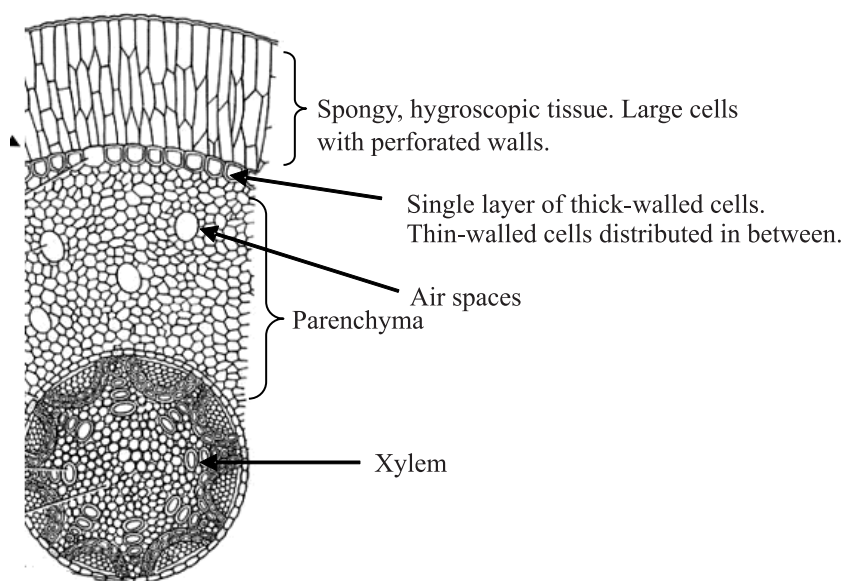

- (a) Stilt root of maize plant  
 (b) Pneumatophore of halophyte  
 (b) Hanging root of an orchid  
 (d) Root of a Pteridophyte

21. During denaturation, globular protein becomes :
- (a) Insoluble and inactive                      (b) Inactive but soluble  
 (c) Unfolded and more soluble                (d) Soluble
22. The process of speciation is depicted in the adjoining figure with three factors that influence speciation. Identify the type of speciation that would explain the evolution of new species (marked with dark circle) from the original species (marked with white circle).

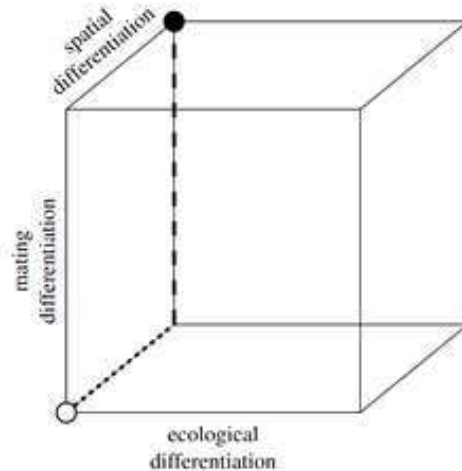

- (a) Sympatric speciation                      (b) Reproductive isolation  
 (c) Allopatric speciation                      (d) Parapatric speciation
23. Erythrocyte sedimentation rate (ESR) is a common hematology test performed using blood containing anticoagulant. It measures the rate at which the red blood cells (RBCs), in a sample of whole blood, fall to the bottom inside a specific tube, under gravity. This sedimentation is due to rouleau formation where RBCs form a stack because of their discoid shape. Which of the following statements about ESR is correct ?
- (a) Inflammatory conditions cause increase in “Acute Phase Proteins” in plasma, that cause the RBCs to repel from each other to form stacks.  
 (b) Increase in positively charged plasma proteins, increases neutralization of the negative charges on the surface of the RBCs, which allows the formation of the rouleaux.  
 (c) Bacterial endotoxins in plasma inhibit platelet aggregation causing RBC to clump.  
 (d) Anticoagulants in the blood increase the negative ions in plasma which increases charges on RBC membranes causing them to stack and form the rouleaux.

24. The adjoining figure is a transverse section of root of a monocot plant showing the stele. Identify the part pointed by arrow.

- (a) Adventitious root                      (b) Lateral root  
 (c) Tap root                                      (d) Adventitious bud

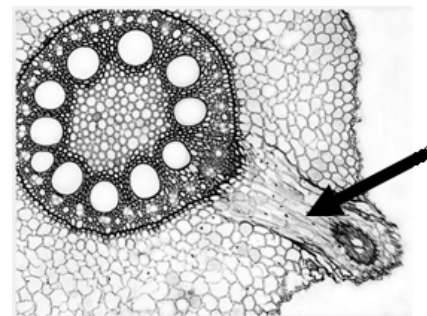

25. Evolutionary branching in a bird population is depicted in the figure below. Based on their phenotype (Bill size), the individuals compete for resources (seeds of different sizes). An individual can utilize only a limited fraction (indicated by the dashed curve) of the total available resources (solid curve).

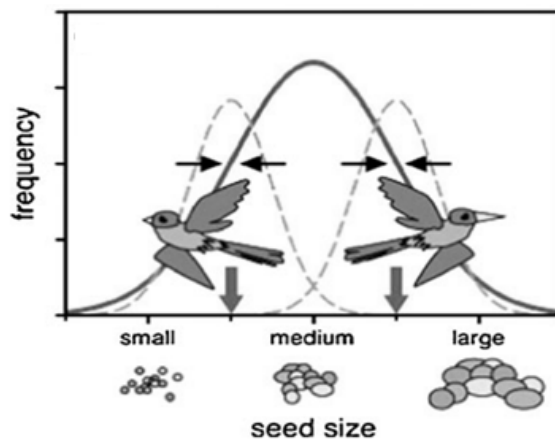

- Which of the following statements most appropriately describes the current status of the bird population, as shown in the figure?
- The mean bill size in the population does not match the most abundant resource, and therefore selection pushes the bill size to an intermediate value.
  - The resources in the middle of the distribution curve are unutilized providing a new ecological niche to evolve in future.
  - Since resources in the tails of the distribution curve are left unexploited, selection establishes individuals with either small or large beak sizes.
  - Selection pressure splits the population into two ecological specialists that evolve an optimal compromise of foraging on the most abundant seeds and avoid competition.
26. A student in a biochemistry lab found three solutions in unlabelled beakers on his working table. He marked the beakers as P, Q and R and found that the  $H^+$  concentration (moles per litre) of the three solutions was  $10^{-4}$ ,  $10^{-7}$  and  $10^{-10}$  respectively. The solutions P, Q, and R respectively could be:
- Baking soda; sea water and beer
  - Stomach acid; household ammonia and detergent
  - Tomato juice; human blood and milk of magnesia
  - Beer; human urine and vinegar
27. Most ants, bees and wasps exhibit haplodiploidy wherein males are haploid and develop from unfertilized eggs while females are diploid and develop from fertilized eggs. Which of the following would be true if the genetic relatedness between two daughters from the same mother in humans and ants are compared?
- The genetic relatedness will be:
- less by a factor of 0.5 in ants.
  - same in both cases.
  - greater by a factor of 0.25 in ants.
  - greater by a factor of 0.5 in ants.

28. Urea is used to produce conformational changes in protein and these changes can be studied using fluorescence emission spectroscopy. In the adjoining figure changes in fluorescence emission is shown for different excitation wavelengths for a protein both in the absence (dotted line) and in the presence (solid line) of urea. Which of the excitation wavelengths marked as I, II, III and IV will be the best one to study the conformational changes?

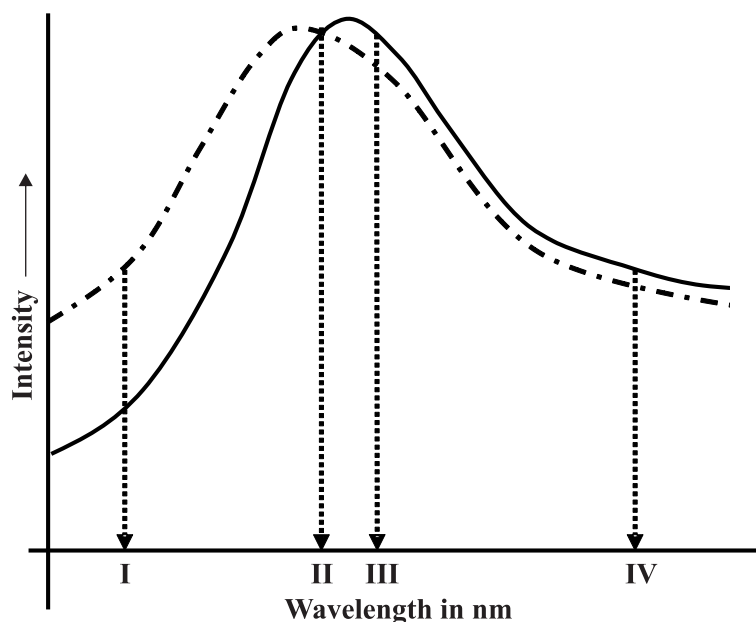

- (a) I                      (b) II                      (c) III                      (d) IV
29. In a classic experiment, scientists selected fruit flies with many bristles (stiff, hairlike structures) on their abdomen. At the start of the experiment, the average number of bristles was 9.5. In each of the successive generations, scientists picked out 20% of the population with the greatest number of bristles and allowed them to reproduce. After 86 generations of such selection, the average number of bristles had quadrupled, to nearly 40. This is an example of:
- (a) Disruptive selection                      (b) Natural selection  
(c) Stabilizing selection                      (d) Directional selection.
30. Warm blooded animals have mechanisms evolved for insulating their bodies. Choose the option that correctly depicts the increasing order of relative insulation that these body parts/components provide.
- (a) Fat; Muscle; dry fur                      (b) Muscle; fat; dry fur  
(c) Muscle; dry fur; fat                      (d) Dry fur; muscle; fat
31. Which of the following is NOT TRUE about DNA polymerase-I ?
- (a) It helps in the removal of primer and subsequent gap filling.  
(b) It has both 5' to 3' and 3' to 5' exonuclease activity.  
(c) It has low processivity and polymerization rate.  
(d) It has only 5' to 3' exonuclease activity

32. The key characteristics that emerged during plant evolution are shown. P, Q and R respectively indicate:

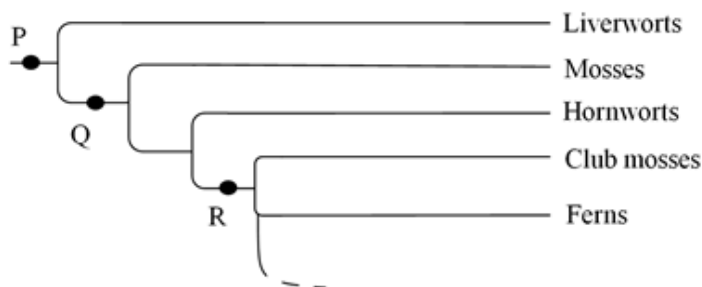

- (a) P: Persistent green sporophyte, Q: Protected embryos, R: Stomata  
 (b) P: Stomata, Q: Microphylls, R: Tracheids  
 (c) P: Microphylls, Q: Persistent green sporophyte, R: Stomata  
 (d) P: Protected embryos, Q: Stomata, R: Tracheids
33. The given figure is transverse section of a stem of *Trifolium repens* (White Clover), a flowering plant, with *Cuscuta epithymum* growing on its stem. Identify the part pointed by arrows.

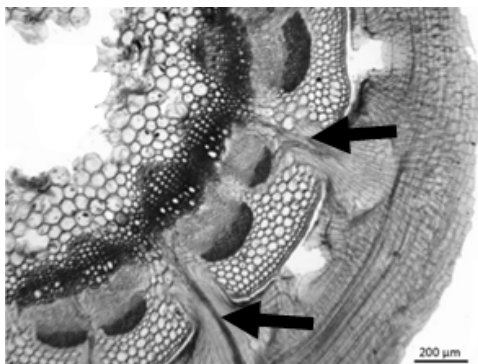

- (a) Cork cambium  
 (b) Haustorium of parasite  
 (c) Secondary phloem  
 (d) Vascular cambium
34.  $\text{Na}^+ - \text{K}^+$  ATPase is essential for maintaining various cellular functions and its inhibition could result in diverse pathologic states.  $\text{Ca}^{2+}$  transport in cardiac muscles is also linked to  $\text{Na}^+ - \text{K}^+$  ATPase. Cardiac glycosides such as digoxin directly inhibit the  $\text{Na}^+ - \text{K}^+$  ATPase. With respect to cardiac muscles, which of the following statements are correct events after digoxin inhibition of  $\text{Na}^+ - \text{K}^+$  ATPase?
- (a) Build-up of excessive  $\text{K}^+$  extracellularly, and depletion of intracellular  $\text{Na}^+$ .  
 (b) Build-up of  $\text{Ca}^{2+}$  intracellularly leading to increased cardiac contractility.  
 (c) Inhibition  $\text{Na}^+ - \text{K}^+$  ATPase stimulates the vagus nerve, causing an increase in heart rate.  
 (d) Changes in  $\text{Na}^+$  ion concentration increases conduction of atrioventricular node causing stimulation of the sinoatrial node.

35. In insects, it has been found that change in the Ubx gene resulted in modifying a protein that blocks the development of legs in the abdominal region. Among the positions indicated as P, Q, R, and S in the cladogram, where the Ubx gene seems to have mutated?

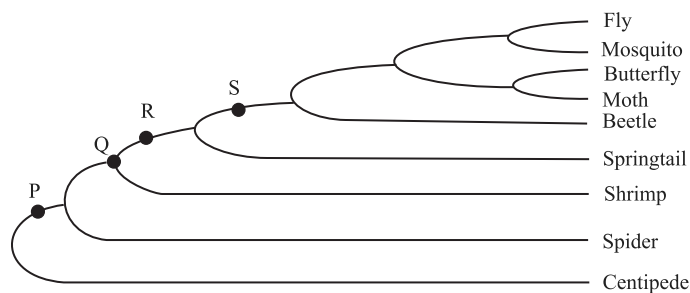

- (a) P                                      (b) Q                                      (c) R                                      (d) S

36. What type of gene is involved in the inheritance pattern depicted in the adjoining human pedigree?

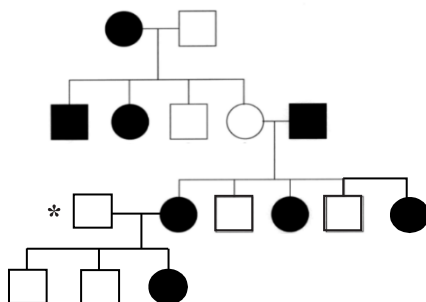

\* Note: the person from outside the family does not carry a defective allele.

- (a) X linked recessive                                      (b) Y linked recessive  
(c) X linked dominant                                      (d) Autosomal recessive
37. The concentration of four components of air during respiration is provided in the table;

Gas (Pressure in Hg mm)	Air in inhalation	Air in exhalation	Air in Alveolus	Arterial blood	Venous Blood
1	158.25	116	100	95	37
2	5.0	47	47	47	47
3	596	568	573	573	573
4	0.3	28	40	40	46

Match the gases 1, 2, 3, and 4 with their names.

- (a) 1 – Carbon dioxide, 2 – Water vapour, 3 – Nitrogen, 4 – Oxygen.  
(b) 1 – Oxygen, 2 – Carbon dioxide, 3 – Nitrogen, 4 – Water vapour.  
(c) 1 – Oxygen, 2 – Water vapour, 3 – Nitrogen, 4 – Carbon dioxide.  
(d) 1 – Nitrogen, 2 – Water vapour, 3 – Oxygen, 4 – Carbon dioxide.

38. A student was following an enzyme catalyzed reaction. As the reaction progressed, she obtained the following graph showing the conversion of the substrate into the product.

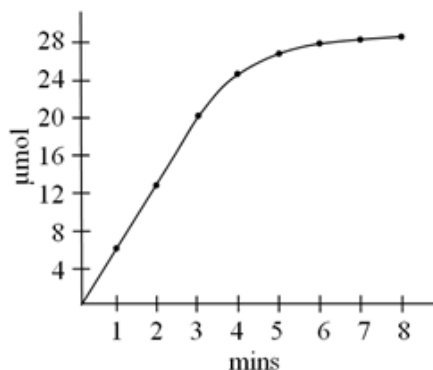

Which of the following is the correct method to calculate product formed per minute?

- (a)  $[(\mu\text{moles})_{3\text{min}} - (\mu\text{moles})_{1\text{min}}]/2$       (b)  $[(\mu\text{moles})_{8\text{min}} - (\mu\text{moles})_{7\text{min}}]$   
 (c)  $[(\mu\text{moles})_{8\text{min}} - (\mu\text{moles})_{1\text{min}}]/7$       (d)  $[(\mu\text{moles})_{5\text{min}} - (\mu\text{moles})_{0\text{min}}]/5$
39. Which of the following figures (marked a, b, c, and d) appropriately depict the relationship of (P) oxygen content of water, (Q) oxygen consumption of resting fish and (R) oxygen consumption of active fish with respect to water temperature?

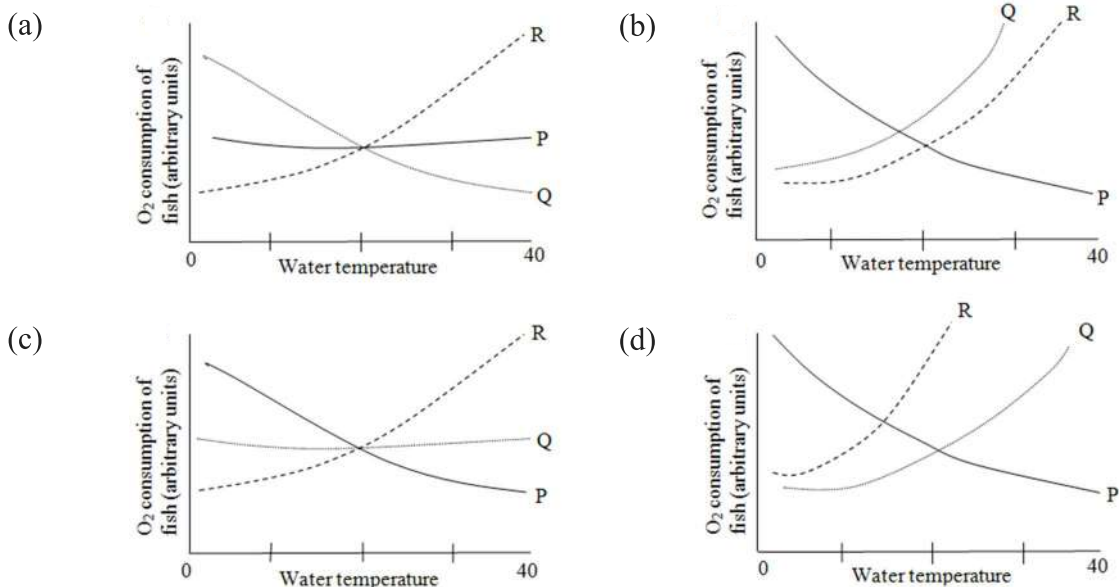

40. Colonisation of drier terrestrial habitats became possible in birds and mammals due to development of the renal system to manage osmotic concentration of urine. Which of the following adaptation is the most crucial for this development ?
- (a) Insertion of aquaporins into the luminal plasma membrane.  
 (b) Differentiation of the kidney into the cortex and medulla  
 (c) Appearance of Henle's loops.  
 (d) Increase in renal circulation.



43. Electrophoresis was carried out to test the efficacy of an anticancer drug. In lane 1- circular DNA sample alone, in lane 2 - DNA mixed with topoisomerase, and in lane 3 - DNA+ topoisomerase mixed with the anticancer drug were loaded in the wells of an agarose gel and electrophoresed. The result was as follows.

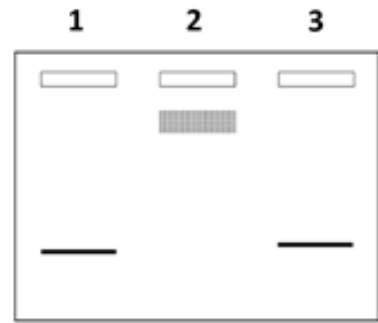

What can be the possible mechanism of action of the drug?

- (a) The drug is likely to act by protecting the cells from damage.  
 (b) The drug is likely to affect topoisomerase I and helping DNA repair mechanism.  
 (c) The lane I and III represent intact supercoiled DNA thus indicating no effect of the drug.  
 (d) The drug is likely to be effective by inhibiting topoisomerase I enzyme that helps in DNA repair at multiple check points.
44. The blood in the capillaries has both a greater hydrostatic and greater osmotic pressure than the surrounding tissue fluid. The difference in hydrostatic pressure tends to force water and dissolved materials out of the capillaries into the tissue fluid while the difference in the osmotic pressure has the opposite effect, causing the capillaries to take up water and the dissolved materials from the tissue fluid. If the osmotic pressure differential at the arteriole and the venule ends are 25mm Hg each; then what would be the expected hydrostatic pressure differentials at the arteriole and venule ends respectively to result in 11mm Hg net outward pressure and 10 mmHg net inward pressure respectively?
- (a) 36 and 35                      (b) 16 and 15                      (c) 16 and 35                      (d) 36 and 15
45. The response of the rates of photosynthesis (curve A) and respiration (curve B) to temperature is depicted in the graph.

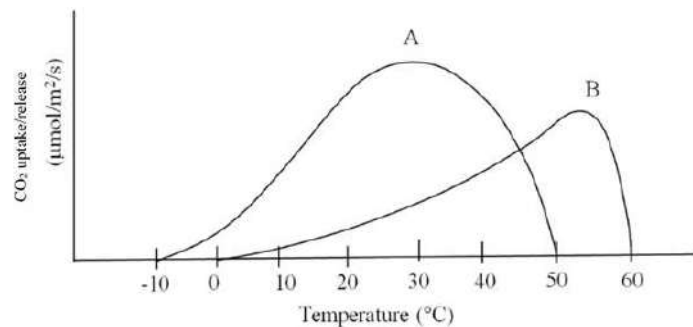

The optimal temperature for net photosynthesis is:

- (a) Between 10°C – 20°C                      (b) Between 20°C – 30°C  
 (c) 32°C    (d) Between 40°C – 50°C

46. In the figure given below identify the type of transport across membrane (marked A, B, C, and D) that needs maximum energy.

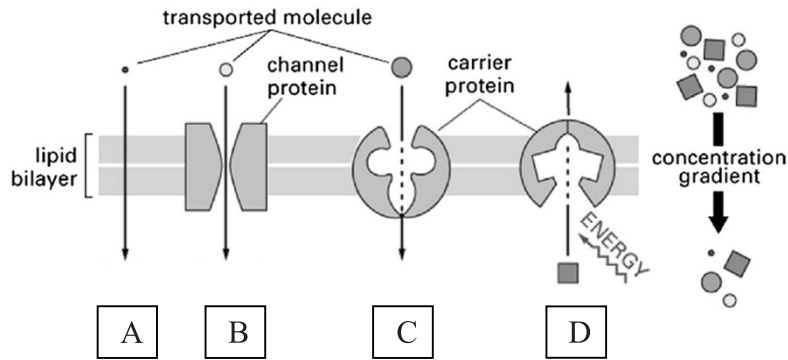

- (a) A                                      (b) B                                      (c) C                                      (d) D

47. Hydronephrosis is a condition in which kidneys become swollen due to incomplete emptying of the urinary tract. Given below are the values of water content and some major electrolytes in four different tissue samples. One of them is normal kidney. Identify the other three and match the right alphabet with the respective number.

Values per Kg fat free tissue	Water (gm)	K (mM)	Na (mM)	Cl (mM)
Normal Kidney	802.2	58.3	82.6	67.7
1.	765	82.1	32.4	21.5
2.	922	3.72	142.0	109.0
3.	830.1	56.4	77.3	53.0

i. Hydronephrotic Kidney

ii. Muscle

iii. Serum

(a) 1. – ii, 2. – iii, 3. – i.

(b) 1. – i, 2. – ii, 3. – iii.

(c) 1. – iii, 2. – ii, 3. – i.

(d) 1. – iii, 2. – i, 3. – ii.

48. Curves I, II and III in the graph represent the impact of inbreeding on the percentage of homozygotes in the successive generations.

The types of breeding represented by the curves I, II and III respectively are:

- (a) Brother – sister mating; mating of first cousins; self-fertilization  
 (b) Mating of first cousins; brother-sister mating; self-fertilization  
 (c) Self-fertilization; brother-sister mating; mating of first cousins  
 (d) Self-fertilization; mating of first cousins; brother-sister mating

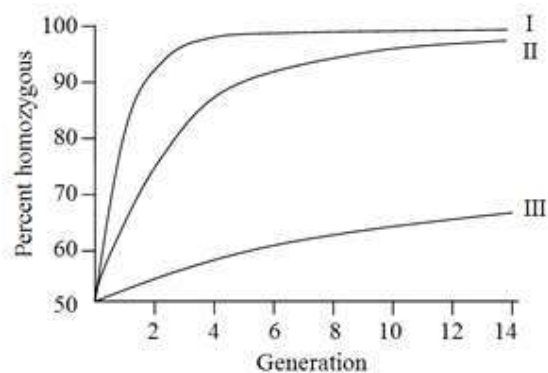

ANY NUMBER OF OPTIONS 4, 3, 2 or 1 MAY BE CORRECT  
MARKS WILL BE AWARDED ONLY IF ALL THE CORRECT OPTIONS ARE BUBBLED

49. The figure below depicts glucose transport into intestinal cells. Study the figure carefully and identify the correct statements.

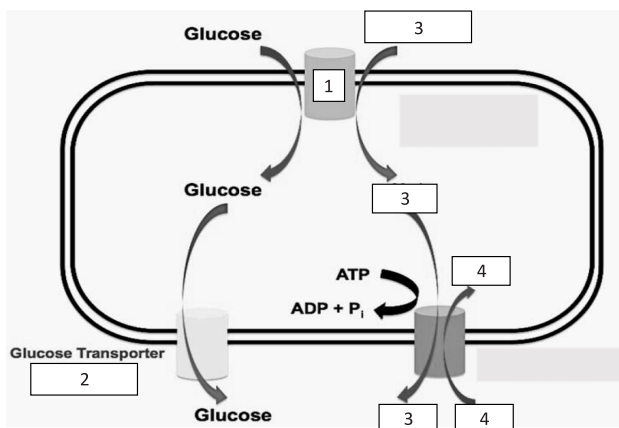

- (a) 1 is a Uniport Transporter while 2 is a Symport Transporter  
 (b) 1 is a Symport Transporter while 2 is a Uniport Transporter  
 (c) 3 is Na<sup>+</sup> ions While 4 is K<sup>+</sup> ions.  
 (d) 3 is K<sup>+</sup> ions and 4 is Na<sup>+</sup> ions.
50. Since the characters fundamental to land plants first appeared in bryophytes, the key to understand transition of plants from aquatic to terrestrial habitats can be found in bryophytes. Which of the following Statements are in consonance with this hypothesis?
- (a) Stomata are seen originally as a sporangial specialization, but in some bryophytes it is also expressed in the sporophyte vegetative body.  
 (b) In most of the bryophytes, rhizoid formation is restricted to the gametophyte.  
 (c) The cell walls of bryophytes contain lignin-related polyphenolic compounds as protection against UV irradiation and attack by micro-organisms.  
 (d) The mature gametophyte is a thallus or a leafy shoot in liverworts, a leafy shoot in mosses and a thallus in hornworts.
51. Renal portal system in reptiles drains the posterior part of the body into the kidney. In this context, with respect to reptilian body, which of the following statements are correct?
- (a) Drug molecule injected in muscles of the front legs and the same drug molecule injected in muscles of hind legs can show different concentrations in circulating blood.  
 (b) Pharmacokinetics of a drug molecule will be same when administered in the vein of front legs or the tail vein.  
 (c) All drug molecules injected through the tail vein will show first site of metabolism in the liver.  
 (d) Drugs which are nephrotoxic should be injected in the front legs to reduce toxicity.

52. *Eumeces okadae* is an endemic skink of the Izu Islands in Japan. Growth and reproduction of female *Eumeces okadae* living on two islands is shown in the adjoining figure. The island of Oh-shima has richest predator fauna including weasels, snakes, and birds while Miyake-jima has only avian predators.

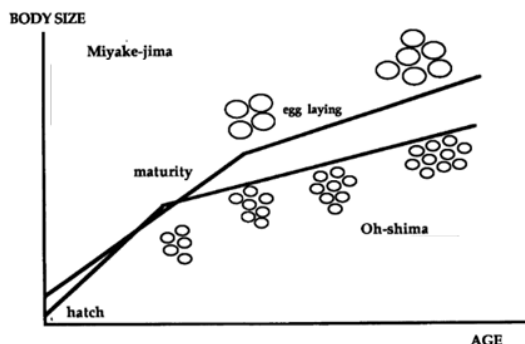

- Choose the correct statement from the following;
- Divergence in the life history traits is influenced mainly by the age of maturity of the breeding individual.
  - Populations in the island of Miyake-jima show a life history with late maturity with low fecundity.
  - Heavy predation leads to a life history with late maturity and high fecundity.
  - The divergence in life history traits is influenced by the age specificity and intensity of predation regime.
53. Evolution of marine fishes shows that fish species have abandoned glomeruli to produce urine by tubular mechanisms. Agglomerular kidney lacks not only glomeruli but also the distal tubules. If agglomerular marine toadfish (*Opsanus tau*) is shifted to 10% sea water, it can survive upto several months. Which of the following event(s) could be taking place in the fish during acclimatisation to dilute sea water?
- Urine flow rate decreases.
  - Kidney starts excreting solutes.
  - The plasma osmotic pressure will increase.
  - Significant branchial and intestinal solute uptake mechanisms set in.
54. Even in passive diffusion, energy is required for the solute to cross a bilayer membrane. This energy is related to the energy of hydration for the solute. Listed below are some solutes, in the context of which, choose the correct statement(s) from the following;

---

**Solute**

---

Glycol (HO-CH<sub>2</sub>-CH<sub>2</sub>-OH)

Glycerol (HO-CH<sub>2</sub>-CH(OH)-CH<sub>2</sub>-OH)

Erythritol (HO-CH<sub>2</sub>-CH(OH)-CH(OH)-CH<sub>2</sub>-OH)

---

- Glycol will diffuse fastest through a bilayer membrane amongst the three solutes listed
- Erythritol will diffuse fastest through a bilayer membrane amongst the three solutes listed
- The solute must first lose its waters of hydration, diffuse across the bilayer membrane, and then regain its waters on the opposite side.
- As the number of waters of hydration increases the activation energy for diffusion decreases.

55. The lineage of cells of immune system are shown below in the figure. Identify the cells marked I, II, III and IV from the statements given.

- (a) I is a T Lymphocyte while II is a B Lymphocyte.  
 (b) I is a B Lymphocyte while II is a T Lymphocyte.  
 (c) III is a granulocyte while IV is a macrophage.  
 (d) III is a macrophage while IV is a granulocyte.

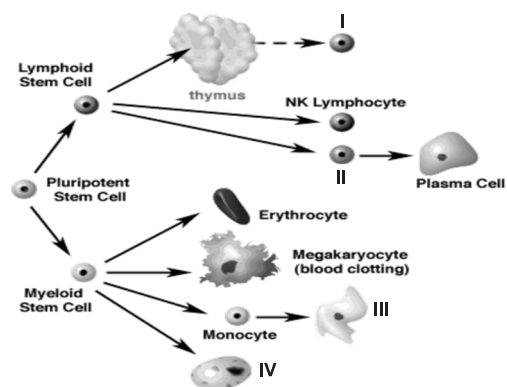

56. C4 photosynthesis is a complex physiological adaptation that confers greater productivity than the ancestral C3 photosynthetic type in environments where photorespiration is high. Identify correct statements related to the C4 physiology.
- (a) In C4 plants there is a temporal separation of CO<sub>2</sub> fixation and synthesis of glucose.  
 (b) Leaf has functionally closely connected, discrete compartments, with a relatively large compartment to host the Calvin cycle.  
 (c) For adapting to arid areas, C4 plants have co-opted same areas of the leaf, for photosynthesis and for water storage cells.  
 (d) In most C4 plants, the feat of concentrating CO<sub>2</sub> is achieved by confining Rubisco to bundle-sheath cells.
57. A study of the changes in the content of carotenoid pigments of young leaves of cotton in strong and weak light was being carried out. Figure A shows the effects of transferring plants from shade into full sunlight while figure B shows the effects of transfer from sunlight into dark.

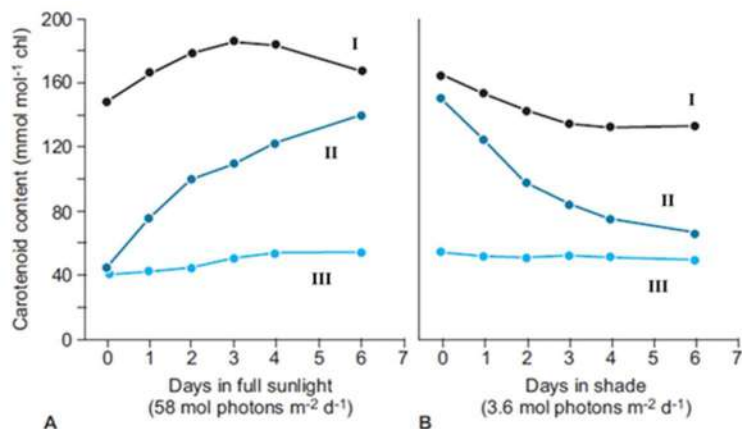

Based on the observations, which of the following statements are true ?

- (a) II could be violaxanthin, which protects thylakoid membrane lipids from photo-oxidation.  
 (b) I could be xanthophylls, which contribute to increasing the light-harvesting capacity of the photosystems.  
 (c) I could be a photoprotector pigment like lutein.  
 (d) III could be a pigment, which is essential for light-gathering in low light intensities.

58. Animal species use various channels to communicate with each other. The selection of a communication channel depends on the ecology of the species and what kind of message the animal wishes to convey to its receivers. A few features of four such modes of communication (numbered 1 to 4) are tabulated below.

	Information available		Cost to sender	
Modes	Fadeout time	Locatability of sender	Broadcast expense	Risk of being caught
1	Fast	Fairly easy	High	Medium
2	Fast	Easy	Low	Low
3	Slow	Difficult	Low	Low
4	Fast	Easy	Low-Moderate	High

Choose the appropriate statements:

- (a) 1 is Tactile signals while 2 is Auditory signal  
 (b) 1 is Auditory signals while 2 is Tactile signal  
 (c) 3 is Chemical signal and 4 is Visual signals.  
 (d) 3 is visual signals and 4 Chemical signals.
59.  $K_m$  values of enzymes provide information about their applications. In this context identify the correct statements from the following;
- (a) A high  $K_m$  value indicates the need for high substrate concentrations in order to achieve maximum reaction velocity.  
 (b) A low  $K_m$  value indicates the need for high substrate concentrations in order to achieve maximum reaction velocity.  
 (c) If two enzymes, with similar  $V_{max}$  in different metabolic pathways compete for the same substrate, then pathway involving enzyme that has the lower  $K_m$  value is likely to be the 'preferred pathway'.  
 (d) If two enzymes, with similar  $V_{max}$  in different metabolic pathways compete for the same substrate, then pathway that has enzyme with the higher  $K_m$  value is likely to be the 'preferred pathway'.

60. Honey bee (*Apis mellifera*) is able to produce heat endothermically and is one of the main reasons for the wide distribution of this species as it allows the whole colony to survive cold winters. Young bees, however, are ectothermic and tend to position themselves, within the hive, in areas with the appropriate environmental conditions. In an experimental arena, different group sizes of young bees were introduced separately, where they were exposed to three different temperature zones. The bees were allowed to freely position themselves within these temperature zones and their positions were recorded after 30 minutes. The results are depicted below:

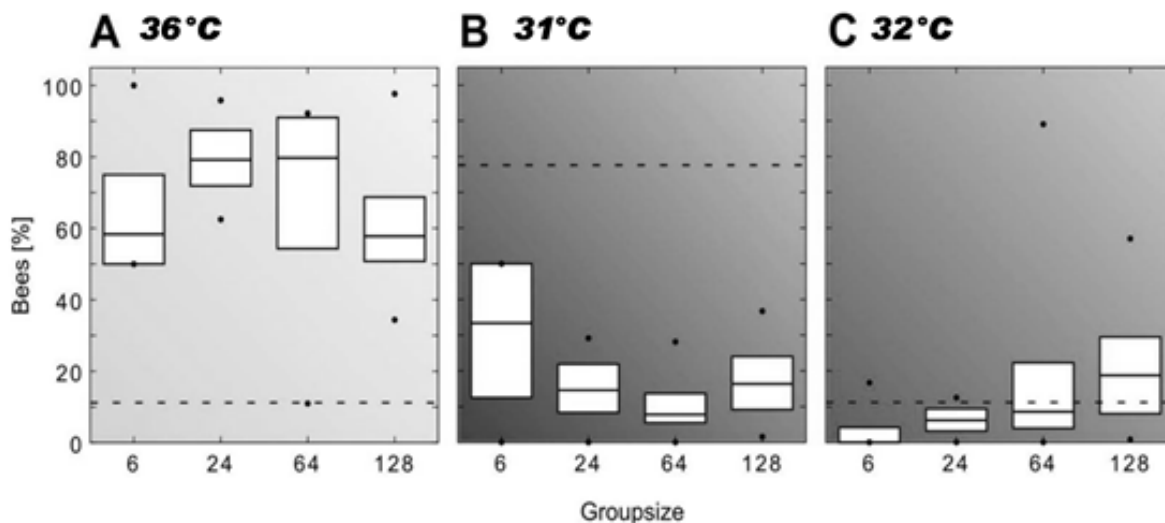

Which of the following statements are correct ?

- The median percentage of bees at 31°C and 32°C temperature areas decreased with increasing group size.
- Irrespective of the group size, 36°C is most likely to be the optimum temperature for the bees.
- There is no significant difference in the preference for cooler temperature areas (31°C and 32°C), in all group sizes of bees.
- In larger groups a percentage of bees may switch to cooler temperature areas (31°C and 32°C) due to crowding effects.

# Rough Work



